

Dynabug®

Tool Manual – Safety, Operation and Maintenance

SAVE THIS DOCUMENT, EDUCATE ALL PERSONNEL

Model:

- 57800** - Non-Vacuum, 8,000, 3/16" Orbit
- 57801** - Self-Generated Vacuum, 8,000, 3/16" Orbit
- 57804** - Central Vacuum, 8,000, 3/16" Orbit
- 57810** - Non-Vacuum, 10,000, 3/32" Orbit
- 57811** - Self-Generated Vacuum, 10,000, 3/32" Orbit
- 57814** - Central Vacuum, 10,000, 3/32" Orbit

Pad: Vinyl

- 3-2/3" x 7"
- 3-2/3" x 7"
- 3-2/3" x 7"
- 3-2/3" x 7"
- 3-2/3" x 7"
- 3-2/3" x 7"



FIND THE MOST CURRENT OFFERING OF SUPPORT DOCUMENTS AND ACCESSORIES @ WWW.DYNABRADE.COM

⚠ WARNING

Read and understand this tool manual before operating your air tool. Follow all safety rules for the protection of operating personnel as well as adjacent areas. Always operate, inspect and maintain this tool in accordance with the American National Standards Institute (ANSI) Safety Code for Portable Air Tools – B186.1. For additional safety information, refer to Safety Requirements for the Use, Care and Protection of Abrasive Wheels – ANSI B7.1, Code of Federal Regulation – CFR 29 Part 1910, European Committee for Standards (EN) Hand Held Non-Electric Power Tools – Safety Requirements and applicable State and Local Regulations.

SAFETY LEGEND

	⚠ WARNING Read and understand tool manual before work starts to reduce risk of injury to operator, visitors, and tool.	⚠ WARNING Practice safety requirements. Work alert, have proper attire, and do not operate tools under the influence of alcohol or drugs.	
	⚠ WARNING Eye protection must be worn at all times, eye protection to conform to ANSI Z87.1.	⚠ WARNING Ear protection to be worn when exposure to sound, exceeds the limits of applicable Federal, State or local statutes, ordinances and/or regulations.	
	⚠ WARNING Respiratory protection to be used when exposed to contaminants that exceed the applicable threshold limit values required by law.	⚠ WARNING Air line hazard, pressurized supply lines and flexible hoses can cause serious injury. Do not use damaged, frayed or deteriorated air hoses and fittings.	

⚠ WARNING

Some dust created by grinding, drilling, and other construction activities contain chemicals known to cause cancer, birth defects or other reproductive harm. Some examples of these chemicals are:

- Lead from lead-based paints
- Crystalline silica from bricks and cement and other masonry products
- Arsenic and chromium from chemically treated lumber

Your risk from these exposures varies, depending on how often you do this type of work. To reduce your exposure to these chemicals: work in a well ventilated area, and work with approved safety equipment, such as those dust masks that are specially designed to filter out microscopic particles.

SAFETY INSTRUCTIONS

Carefully Read all instructions before operating or servicing any Dynabrade® Abrasive Power Tool.

Products offered by Dynabrade are not to be modified, converted or otherwise altered from the original design without expressed written consent from Dynabrade, Inc.

Tool Intent: Dynabug® Sander is used for sanding and finishing a variety of materials including wood, metal, plastic, fiberglass, solid surfaces, composites, rubber, glass and stone.

Do not use tool for anything other than its intended applications.

This power tool is not intended for use in potentially explosive atmospheres and is not insulated against contact with electrical power.

Training: Proper care, maintenance, and storage of your tool will maximize its performance.

- Employer's Responsibility – Provide Dynabug® operators with safety instructions and training for safe use of tools and accessories.

Accessory Selection:

- Use 3-2/3" x 7" PSA abrasives directly adhered to pad or 3-2/3" x 9" Non-PSA abrasives for use with clips.

(continued on next page)

Maintenance Instructions

Important: To keep power tool safe a Preventative Maintenance Program is recommended whenever portable power tools are used.

- Use only genuine Dynabrade replacement parts to insure quality. To order replacement parts, specify **Model#**, **Serial#** and **RPM** of your air tool.
- It is strongly recommended that all Dynabrade rotary vane air tools be used with a Filter-Regulator-Lubricator to minimize the possibility of misuse due to unclean air, wet air or insufficient lubrication. Dynabrade recommends the following: **10681** Air Filter-Regulator-Lubricator (FRL) – Provides accurate air pressure regulation and two stage filtration of water contaminants.
- Dynabrade recommends one drop of air lube per minute for each 20 SCFM (example: if the tool specification states 40 SCFM, set the drip rate on the filter-lubricator to 2 drops per minute). Dynabrade Air Lube (P/N **95842**: 1 pt 473 ml) is recommended.
- **BEFORE MOUNTING AN ACCESSORY**, after all tool repairs and whenever a tool is issued for use, check tool OPM (speed) with tachometer with air pressure set at 90 PSIG while the tool is running.

Routine Preventative Maintenance: Check free speed of Dynabug® regularly using either a strobe or magnetic tachometer. If tool is operating at a higher speed than the RPM marked on the tool housing, or operating improperly, the tool must be serviced and corrected before use..

- Mineral spirits are recommended when cleaning the tool and parts. Do not clean tool or parts with any solvents or oils containing acids, esters, ketones, chlorinated hydrocarbons or nitro carbons.
- DO NOT clean or maintain tools with chemicals that have a low flash point (example: WD-40®).
- Air tool stampings must be kept legible at all times, if not, reorder and replace. User is responsible for maintaining specification information i.e.: Model #, S/N, and RPM.
- Blow air supply hose out prior to initial use.
- Visually inspect air hoses and fittings for frays, visible damage and signs of deterioration. Replace damaged or worn components.
- Refer to Dynabrade's Warning/Safety Operating Instructions Tag (Reorder No. **95903**) for safety information.

After maintenance is performed on tool, add a few drops of Dynabrade Air Lube (P/N **95842**) to the air line and start the tool a few times to lubricate air motor. Check for excessive tool vibration.

Handling and Storage:

- Protect tool inlet from debris (See Notice Below).
- DO NOT carry tool by air hose.
- Protect abrasive accessories from exposure to water, solvents, high humidity, freezing temperature and extreme temperature changes.
- Store accessories in protective racks or compartments to prevent damage.

Notice

All Dynabrade motors use the highest quality parts and materials available and are machined to exacting tolerances. The failure of quality pneumatic motors can most often be traced to an unclean air supply or the lack of lubrication. Air pressure easily forces dirt or water contained in the air supply into motor bearings causing early failure. It often scores the cylinder walls and the rotor blades resulting in limited efficiency and power. Our warranty obligation is contingent upon proper use of our tools and cannot apply to equipment which has been subjected to misuse such as unclean air, wet air or a lack of lubrication during the use of this tool.

Lifetime Warranty

All Dynabrade portable pneumatic power tools are rigorously inspected and performance tested in our factory before shipping to our customers. If a Dynabrade tool develops a performance problem and an inherent defect is found during normal use and service, Dynabrade will warrant this tool against defects in workmanship and materials for the lifetime of the tool. Upon examination and review at our factory, Dynabrade shall confirm that the tool qualifies for warranty status, and will repair or replace the tool at no charge to the customer. Normally wearable parts and products are NOT covered under this warranty. Uncovered items include bearings, contact wheels, rotor blades, regulators, valve stems, levers, shrouds, guards, O-rings, seals, gaskets and other wearable parts. Dynabrade's warranty policy is contingent upon proper use of our tools in accordance with factory recommendations, instructions and safety practices. It shall not apply to equipment that has been subjected to misuse, negligence, accident or tampering in any way so as to affect its normal performance. To activate lifetime warranty, customer must register each tool at www.dynabrade.com. Dynabrade will not honor lifetime warranty on unregistered tools. A one-year warranty will be honored on all unregistered portable pneumatic power tools. Lifetime warranty applies only to portable pneumatic tools manufactured by Dynabrade, Inc. in the USA. Lifetime warranty applies only to the original tool owner; warranty is non-transferable.

Machine Specifications

Model Number	Motor hp (W)	Motor RPM	Sound Level	Maximum Air Flow SCFM (LPM)	Air Pressure PSIG (Bars)	Weight Pound (kg)	Length Inch (mm)	Height Inch (mm)
57800	.24 (179)	8,000	80 dB(A)	16 (453)	90 (6.2)	2.8 (1.3)	7-1/4 (184)	4-1/4 (108)
57801	.24 (179)	8,000	83 dB(A)	16 (453)	90 (6.2)	2.8 (1.3)	7-1/4 (184)	4-1/4 (108)
57804	.24 (179)	8,000	80 dB(A)	16 (453)	90 (6.2)	2.8 (1.3)	7-1/4 (184)	4-1/4 (108)
57810	.28 (209)	10,000	80 dB(A)	18 (510)	90 (6.2)	2.8 (1.3)	7-1/4 (184)	4-1/4 (108)
57811	.28 (209)	10,000	81 dB(A)	18 (510)	90 (6.2)	2.8 (1.3)	7-1/4 (184)	4-1/4 (108)
57814	.28 (209)	10,000	80 dB(A)	18 (510)	90 (6.2)	2.8 (1.3)	7-1/4 (184)	4-1/4 (108)

Additional Specifications: Air Inlet Thread 1/4" NPT • Hose Size 1/4" or 6 mm

Sound Level is the pressure measurement according to the method outlined in ISO regulation ISO-15744.

Models:
57800, 57801, 57804
57810, 57811, 57814

Dynabug® Complete Assembly

Index Key		
No.	Part #	Description
1	96258	Screw (4)
2	96168	Screw
3	57834	Rubber Grip (2)
4	95183	Washer
5	57838	Washer
6	96114	Screw (6)
7	94590	Pin (3)
8	57826	Clip Top (2)
9	57840	Clip Spring (2)
10	57825	Pad Top
11	57837	Washer
12	57842	Vacuum Tube
13	57822	Boot
14	57823	Pad Mount
15	96116	Clamp
16	95630	Snap Ring
17	57069	Balancer Shaft
18	95628	Bearing Shield
19	56053	Bearing Seal
20	56052	Balancer Bearing
21	Motor Balancer Shaft	
	57833	3/16" Orbit
	57839	3/32" Orbit
22	56047	Rotor Key
23	57059	Lock Ring Seal
24	95973	Washer
25	57055	Front Ring
26	57088	Bearing
27	57057	Front Bearing Plate
28	57113	Blade (5/pkg.), Rotor Set
29	57058	Cylinder Assembly (Includes 95971 Pin)
30	95971	Line-Up Pin
31	57056	Rear Bearing Plate
32	01206	Bearing
33	57054	Rear Ring
34	95626	Snap Ring
35	Lever	
	57820	3/16" Orbit
	57821	3/32" Orbit
36	01464	Seal
37	01472	Tip Valve
38	01468	Conical Spring
39	01494	Inlet Bushing
40	95697	Snap Ring
41	01025	O-Ring (2)
42	01477	Valve Stem
43	57064	Speed Regulator
44	57041	Comfort Platform

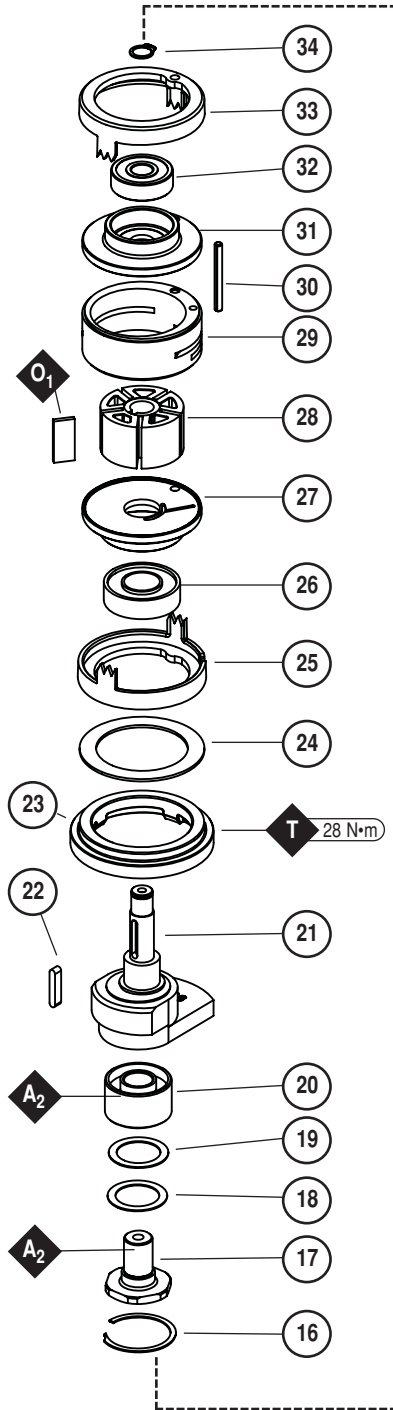

See page 2 for Machine Exhaust Assemblies.

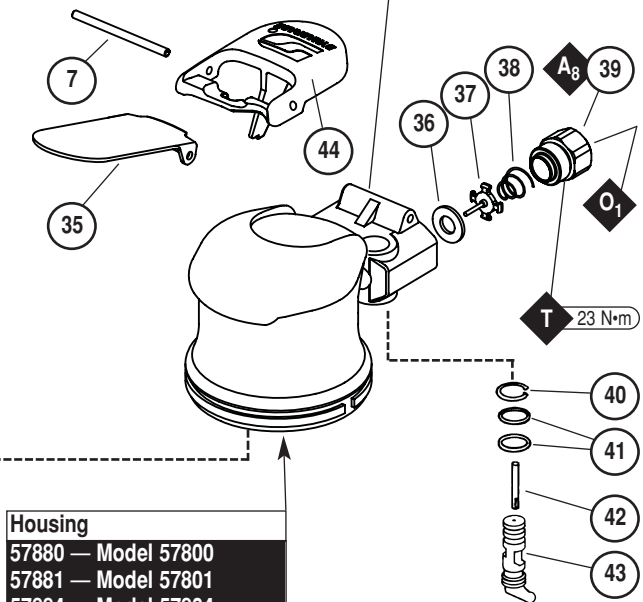

Housing	
57880	— Model 57800
57881	— Model 57801
57884	— Model 57804
57882	— Model 57810
57883	— Model 57811
57886	— Model 57814

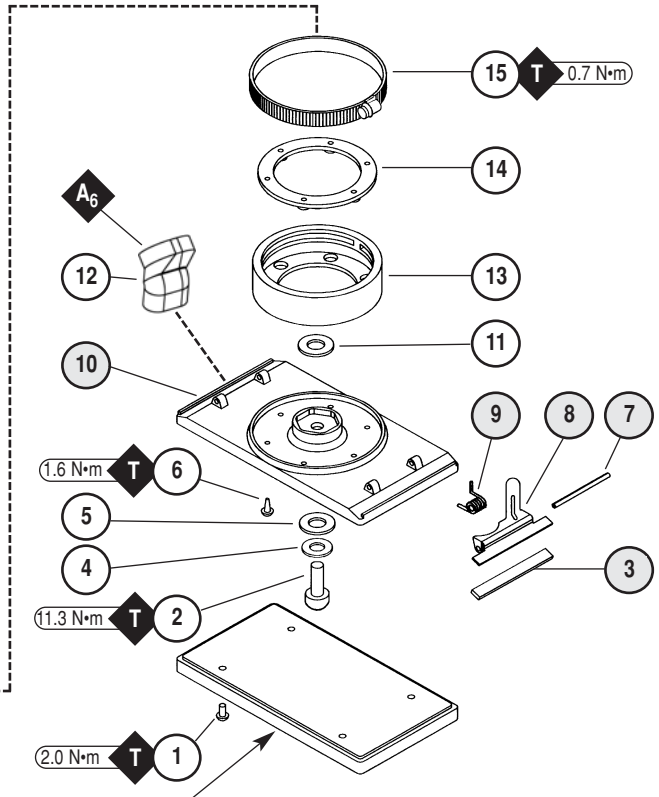

Pads	
57850	Non-Vac, Vinyl-Face
57851	Non-Vac, Hook-Face
57852	Non-Vac, Long nap Hook-Face
57855	Vac, Vinyl Face
57856	Vac, Hook-Face

KEY	
O	Oil: O ₁ = Air Lube
A	Adhesive: A ₂ = Loctite #271 A ₆ = Loctite #380 A ₈ = Loctite #567
T	Torque: N·m x 8.85 = In. - lbs.

Shaded parts represent 57841 Assembly.

Motor Assembly/Disassembly Instructions – Dynabug® Orbital Sander

Important: Manufacturer's warranty is void if tool is disassembled before warranty expires.

A Motor Repair Kit (57098) is available which contains special tools for disassembly/assembly. Please refer to parts breakdown for part identification.

To Disassemble:

1. Disconnect tool from power source. Invert machine and secure in vice, using **57092** Collar (supplied in **57098** Repair Kit) or padded jaws.
2. Disconnect sanding pad by removing **96258** Screws (4) with a 3.0mm wrench.
3. With a Phillips head screw driver remove **96114** Screws (6). Remove **96168** Screw with 3/16" hex wrench, and remove pad top from boot.
4. Disengage **96116** Clamp by using a screwdriver to unscrew clamp. Remove clamp, **57822** Boot and **57823** Pad Mount from housing.
5. Insert **56058** Lock Ring Tool (supplied in **57098** Repair Kit) into corresponding tabs of lock ring and unscrew. Motor may now be lifted out for service.
6. Remove rear ring from motor. Remove **95626** Snap Ring. Upper motor may now be disassembled.
7. Remove the rear plate and the cylinder assembly by securing the cylinder in a bearing separator gripped on the cylinder exhaust and extra pocket area. Push the motor shaft balancer through the bearing.
8. Remove the rotor, vanes and rotor key from the motor shaft balancer. Remove the front plate using a (#2) arbor press. Support the edges of the front plate while pressing on the small end of the motor shaft balancer.
9. a.) If, during step 9, the front plate and bearing remain together, press bearing out of the front plate using **57091** Press Tool (supplied in **57098** Repair Kit).
b.) If, during step 9, the front plate and **57088** Bearing remains on the motor shaft balancer, it can be removed with a bearing separator.
11. Remove **01206** Bearing from the rear plate by using a bearing press tool. Remove lock ring, washer and front ring.
12. Disassemble the balancer assembly as follows:
 - a.) Place motor shaft assembly into a soft jaw vise. Using a thin screwdriver, pick out the end of **95630** Snap Ring and peel out.
 - b.) Screw the threaded portion of the **56056** Bearing Puller (supplied in **57098** Repair Kit) into the **57069** Balancer Shaft and heat the outside of the motor shaft balancer to approximately 200° F (approximately 10 seconds with a propane torch). Now, using the slider weight, pull the assembly out.
 - c.) Press off **56052** Bearing with a bearing separator and remove bearing seal and bearing shield.
13. If during step 12, the **56052** Bearing remains in the motor shaft balancer, it can be removed by heating the shaft balancer again and using either an inside bearing puller or a blind hole bearing puller.

Tool Disassembly Complete.

To Assemble

Important: Be certain parts are clean and in good repair before assembling.

1. Assemble the balancer assembly as follows:
 - a.) Install **95630** Snap Ring onto **57069** Balancer Shaft. Install **95628** Shield with convex face toward hex of balancer shaft. Install **56053** Seal.
Note: Be certain seal is pressed completely over shaft step.
 - b.) Apply 1 drop of Loctite® #271 (or equivalent) and spread over several places around the inside diameter of the **56052** Bearing and the outside diameter of the **57069** Balancer Shaft.
 - c.) Press fit **56052** Bearing with seal side toward hex of balancer shaft up to shaft step. This must be a firm press fit for proper retention of bearing.
2. Place the motor shaft balancer in a soft jaw vise with large end-up.
3. Apply 1 drop of Loctite® #271 (or equivalent) and spread over several places around the outside diameter of the **56052** Bearing and slide balancer assembly into the motor shaft balancer until **56052** Bearing is firmly seated at bottom. Squeeze **95630** Snap Ring into groove in motor shaft balancer to complete the assembly. Remove from vise.
4. Press **57088** Bearing onto the motor shaft balancer down to the shoulder. Place lock ring, washer and front ring on motor shaft balancer.
5. Press **57057** Front Bearing Plate onto **57088** Bearing and check for smooth rotation.
6. Place the **57090** Rotor and **56047** Rotor Key on the motor shaft balancer. Place the **56073** Vanes into the rotor slots.
Note: Vanes should be lightly lubricated with Dynabrade Air Lube P/N **95842** (or equivalent) before installation into the rotor slots.
7. Place **57058** Cylinder Assembly over rotor. The "short" line-up pin goes toward the front plate.
8. Place **57056** Rear Bearing Plate (with bearing pressed into place) over shaft and "long" end of line-up pin and press fit in place. Insert **95626** Snap Ring.
9. Place **57054** Rear Ring over the rear plate and line-up pin. Make sure that the "legs and fingers" on the front and rear rings line-up.
10. Secure motor housing in vise, using **57092** Collar or padded jaws. Spread 2-3 drops of pneumatic tool oil around the housing bore and slide motor assembly in housing. **Note:** Be certain line-up pin enters the pocket in bottom of the housing and the "legs" of the rings stay in line.
11. Tighten lock ring with **56058** Lock Ring Tool torque to 28 N•m/250 in. - lbs.
12. Insert **57823** Pad Mount into boot. Attach boot to housing with exhaust hole facing back and slide clamp over boot.
13. Place **57837** Washer into hex pocket with shoulder down. Line-up holes in pad top with holes in boot and secure with **96114** Screws (6).
14. Secure pad top and boot to motor assembly by installing **57838** Washer, **95183** Washer and **96168** Screw through pad top and into balancer shaft.
15. Position pad top to desired angle and tighten clamp to 0.7 N•m/6 in. - lbs. so that the top of the clamp is even with the top of the boot.
16. Attach sanding pad by installing **96258** Screws (4).

Valve and Speed Regulator Assemblies:

1. Secure housing in vice using **57092** Collar or padded jaws. Remove inlet bushing, **01468** Spring, **01472** Tip Valve and **01464** Seal from housing.
2. Remove **95697** Snap Ring. Press the speed regulator and valve stem out of the housing. Remove the **01025** O-Rings (2).
3. Place new **01025** O-Rings (2) on the speed regulator and place in housing with valve stem. Install new **95967** Snap Ring.
4. Place seal in housing. Using tweezers or needle nose pliers, place the tip valve in the housing so that its pin goes into the valve stem hole. Place **01468** Spring into the housing so the small end is toward the tip valve.
5. Spread one drop of Loctite® #567 (or equivalent) around the first threads of the first inlet bushing and tighten into housing torque to 23 N•m/200 in. - lbs.

Tool Assembly Complete. Please allow 30 minutes for adhesives to cure before operating tool.

Loctite® is a registered trademark of the Loctite Corp.

Vacuum Conversion Instructions

To Disassemble:

1. Disconnect tool from power source. Invert machine and secure in vise, using **57092** Collar (supplied in **57098** Repair Kit) or padded jaws.
2. Remove **56028** Muffler Cap and **56027** Muffler Insert (3) from **57066** Muffler Body. Using a 12mm hex wrench (supplied in **57098** Repair Kit), remove muffler body and **57065** Cone Muffler from housing (not applicable for self-generated vac to central vac).

Non-Vac to Self-Generated Vac for Hook-Up to Self-Contained Dust Collection System

1. Attach **57083** Vacuum Adapter to **57842** Vacuum Tube. Instructions for Installing the **57842** Dynabug Vacuum Tube (DVT): Use denatured alcohol to clean the mating portion of the **57842** DVT and the mating portion of the vacuum adapter. Apply 4 drops of the Loctite #380 or an equivalent to the mating portion of the **57842** DVT. Install the **57842** DVT onto the vacuum adapter. Adjust the clearance between the end of the **57842** DVT and the pad top so that there is a gap of 1/16" or 1.60 mm. Hold the **57842** DVT until adhesive sets. Once adhesive is set, allow one hour before operating the tool.
2. Place **95526** O-Ring on the muffler body between the shoulder and the four (4) protrusions. Using a 12mm hex wrench, attach the muffler body, cone muffler and o-ring to the housing through the vacuum adapter.
3. Place **57068** Vacuum Nozzle into the vacuum adapter with the slots facing outward making sure that the knob on the nozzle is aligned with the slot in the adapter.
4. Place **57067** Vacuum Tube into the vacuum adapter with the grooves facing inward until the adapter "snaps" onto the tube and the tube cannot be pulled out. If the tube can be pulled out, rotate it 1/4 turn and place it back into the adapter until it "snaps".
5. Rotate tube until holes line up. Insert **96197** Dowel Pin in holes until it is centered.
6. Attach machine to portable dust collection system.

Non-Vac to Central Vac

1. Attach **57093** Vacuum Adapter to **57842** Vacuum Tube. Instructions for Installing the **57842** Dynabug Vacuum Tube (DVT): Use denatured alcohol to clean the mating portion of the **57842** DVT and the mating portion of the vacuum adapter. Apply 4 drops of the Loctite #380 or an equivalent to the mating portion of the **57842** DVT. Install the **57842** DVT onto the vacuum adapter. Adjust the clearance between the end of the **57842** DVT and the pad top so that there is a gap of 1/16" or 1.60 mm. Hold the **57842** DVT until adhesive sets. Once adhesive is set, allow one hour before operating the tool.
2. Using a 12mm hex wrench, attach the muffler body and cone muffler to the housing through the central vacuum adapter.
3. Place muffler cap with inserts on muffler body making sure that the protrusions on the body fit in the pockets on the cap.
4. Attach machine to central vacuum system.

Self-Generated Vac to Central Vac

1. Remove **96197** Dowel Pin with a 1/8" drive pin.
2. Remove **57067** Vacuum Tube from the **57083** Vacuum Adapter by turning it clockwise while pulling backward.
3. Using a small flat screwdriver, pry the **57068** Vacuum Nozzle until it is loose and then remove it by using two fingers to push and pull it until it hits the "legs" on the vacuum adapter. Place the vacuum tube back into the vacuum adapter far enough to push the "legs" back then push the vacuum nozzle and the vacuum tube out the rest of the way.
4. Using a 12mm hex wrench (supplied in **57098** Repair Kit), remove the **57066** Muffler Body, **57065** Cone Muffler and **95526** O-Ring from the housing through the adapter. Remove the o-ring from the muffler body.
5. Remove **57083** Vacuum Adapter and the **57842** Vacuum Tube. Remove the vacuum tube from the vacuum adapter using a small amount of heat and tapping with a hammer. Attach **57093** Vacuum Adapter to **57842** Vacuum Tube. Instructions for Installing the **57842** Dynabug Vacuum Tube (DVT): Use denatured alcohol to clean the mating portion of the **57842** DVT and the mating portion of the vacuum adapter. Apply 4 drops of the Loctite #380 or an equivalent to the mating portion of the **57842** DVT. Install the **57842** DVT onto the vacuum adapter. Adjust the clearance between the end of the **57842** DVT and the pad top so that there is a gap of 1/16" or 1.60 mm. Hold the **57842** DVT until adhesive sets. Once adhesive is set, allow one hour before operating the tool.
6. Using a 12mm hex wrench, attach the muffler body and cone muffler to the housing through the central vacuum adapter.
7. Place muffler cap with inserts on muffler body making sure that the protrusions on the body fit in the pockets on the cap.
8. Attach machine to central vacuum system.

Central Vac to Self Generated Vac

1. Remove **57093** Central Vacuum Adapter and the **57842** Vacuum Tube. Remove the vacuum tube from the vacuum adapter using a small amount of heat and tapping with a hammer. Attach **57083** Vacuum Adapter to **57842** Vacuum Tube. Instructions for Installing the **57842** Dynabug Vacuum Tube (DVT): Use denatured alcohol to clean the mating portion of the **57842** DVT and the mating portion of the vacuum adapter. Apply 4 drops of the Loctite #380 or an equivalent to the mating portion of the **57842** DVT. Install the **57842** DVT onto the vacuum adapter. Adjust the clearance between the end of the **57842** DVT and the pad top so that there is a gap of 1/16" or 1.60 mm. Hold the **57842** DVT until adhesive sets. Once adhesive is set, allow one hour before operating the tool.
2. Place **95526** O-Ring on the muffler body between the shoulder and the four (4) protrusions. Using a 12mm hex wrench (supplied in **57098** Repair Kit), attach the muffler body, cone muffler and o-ring to the housing through the vacuum adapter.
3. Place **57068** Vacuum Nozzle into the vacuum adapter with the slots facing outward making sure that the knob on the nozzle is aligned with the slot in the adapter.
4. Place **57067** Vacuum Tube into the vacuum adapter with the grooves facing inward until the adapter "snaps" onto the tube and the tube cannot be pulled out. If the tube can be pulled out, rotate it 1/4 turn and place it back into the adapter until it "snaps".
5. Rotate tube until holes line up. Insert **96197** Dowel Pin in holes until it is centered.
6. Attach machine to portable dust collection system.

Preventative Maintenance Schedule

For All Dynabug® Sanders

This service chart is published as a guide to expectant life of component parts. The replacement levels are based on average tool usage over one year. Dynabrade Inc. considers one year usage to be 1,000 hours.

Parts Common to all Models:

LEGEND	
T	Included in Tune-Up Kit
X	Type of wear, no other comments apply.
L	Easily lost. Care during assembly/disassembly.
D	Easily damaged during assembly/disassembly.
R	Replace each time tool is disassembled.



96024 – Tune-Up Kit

Index #	Part Number	Description	Number Required	High Wear 100%	Medium Wear 70%	Low Wear 30%	Non-Wear 10%
1	96258	Screw	4		X		
2	96168	Screw	1		X		
3	57834	Rubber Grip	2			X	
4	95183	Washer	1			X	
5	57838	Washer	1			X	
6	96114	Screw	6		X		
7	94590	Pin	3				T
8	57826	Clip Top	2				X
9	57840	Clip Spring	2				X
10	57825	Pad Top	1				X
11	57837	Washer	1			X	
12	57842	Vacuum Tube	1			X	
13	57822	Boot	1	X			
14	57823	Pad Mount	1		X		
15	96116	Clamp	1				X
16	95630	Snap Ring	1		T		
17	57069	Balancer Shaft	1				X
18	95628	Bearing Shield	1				X
19	56053	Bearing Seal	1		X		
20	56052	Balancer Bearing	1		T		
21	See Note	Motor Shaft Balancer	1				X
22	56047	Rotor Key	1		T		
23	57059	Lock Ring Seal	1			X	
24	95973	Washer	1				X
25	57055	Front Ring	1		T		
26	57088	Bearing	1		T		
27	57057	Front Bearing Plate	1			X	
28	57113	Rotor/Blade Set	1	T			
29	57058	Cylinder Assembly	1			X	
30	95971	Line-Up Pin	1		T		
31	57056	Rear Bearing Plate	1			X	
32	01206	Bearing	1		T		
33	57054	Rear Ring	1		T		
34	95626	Snap Ring	1		T		
35	See Note	Lever	1			X	
36	01464	Seal	1		T		
37	01472	Tip Valve	1		T		
38	01468	Conical Spring	1		T		
39	01494	Inlet Bushing	1				X
40	95697	Snap Ring	1		T		
41	01025	O-Ring	2		T		
42	01477	Valve Stem	1		T		
43	57064	Speed Regulator	1			X	
44	57041	Comfort Platform	1				X
45	57083	Vacuum Adapter	1		X		
46	96197	Dowel Pin	1			L	
47	57065	Cone Muffler	1	T			
48	57066	Muffler Body	1			X	
49	95526	O-Ring	1		T		
50	57068	Vacuum Nozzle	1		X		
51	57067	Vacuum Tube	1		X		
52	57093	Vacuum Adapter	1		X		
53	56027	Muffler Insert	See Note	T			
54	56028	Muffler Cap	1		X		

Note: Please refer to page 4 of tool manual for specific part number and description.

Machine Exhaust Assemblies

Self-Generated Vacuum

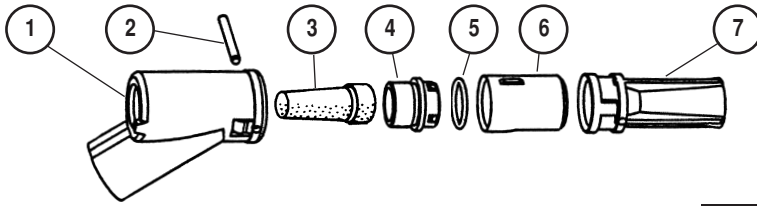

Non-Vacuum

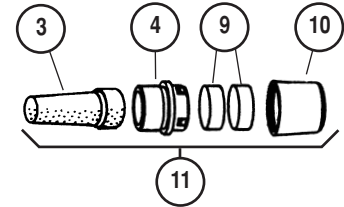

Vacuum-Ready

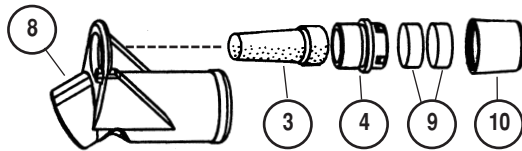

Index Key

No. Part # Description

1	57083	Vacuum Adapter	8	57093	Vacuum Adapter
2	96197	Dowel Pin	9	56027	Muffler Insert Qty 2 - 3/32" Orbit Qty 3 - 3/16" Orbit
3	57065	Cone Muffler	10	56028	Muffler Cap
4	57066	Muffler Body	11	57124	Muffler Assembly
5	95526	O-Ring			
6	57068	Vac Nozzle			
7	57067	Vac Tube			

Optional Accessories

FIND THE MOST CURRENT OFFERING OF SUPPORT DOCUMENTS AND ACCESSORIES @ WWW.DYNABRADE.COM



96024 Motor Tune-Up Kit

- Includes assorted parts to help maintain and repair motor.



96232 (#2) Arbor Press

- This arbor press is ideal for the disassembly and assembly of air motors.



96346 2" Bearing Separator

- Use the separator to remove gears and bearings.



95266 - 3mm Hex Wrench



96343 Retaining Ring Pliers

- Internal/external retaining ring pliers.
Tip diameter - 0.038" (0.96mm)



Dynabrade Air Lube

- Formulated for pneumatic equipment.
- Absorbs up to 10% of its weight in water.
- Prevents rust and formation of sludge.
- Keeps pneumatic tools operating longer with greater power and less down time.

95821: 4 oz. (118 ml)

95842: 1 pt. (473 ml)

95843: 1 gal. (3.8 L)



57098 Repair Kit:

- Contains special tools for disassembly/assembly of machine.



57091 Bearing Press Tool

- This tool is used to push against the I.D. of the bearing.

Reference Contact Information

1. **American National Standards Institute - ANSI**
25 West 43rd Street
Fourth Floor
New York, NY 10036
Tel: 1 (212) 642-4900
Fax: 1 (212) 398-0023

2. **Government Printing Office - GPO**
Superintendent of Documents
Attn. New Orders
P.O. Box 371954
Pittsburgh, PA 15250-7954
Tel: 1 (202) 512-1803

3. **European Committee for Standardization**
Rue de Stassart 36
B - 1050 Brussels, Belgium

Visit Our Web Site: www.dynabrade.com

Email: Customer.Service@Dynabrade.com



DYNABRADE, INC., 8989 Sheridan Drive • Clarence, NY 14031-1490 • Phone: (716) 631-0100 • Fax: 716-631-2073 • International Fax: 716-631-2524
DYNABRADE EUROPE S.à.r.l., Zone Artisanale • L-5485 Wormeldange-Haut, Luxembourg • Telephone: 352 76 84 94 1 • Fax: 352 76 84 95 1

© DYNABRADE, INC., 2009

PRINTED IN USA

PD09.53_10/09