

# 1hp Right-Angle Disc Sander Governor Controlled

*Air Tool Manual – Safety, Operation and Maintenance*

SAVE THIS DOCUMENT, EDUCATE ALL PERSONNEL

**Models:**

- 52560 – 12,000 RPM, 3/8"-24 Spindle
- 52561 – 11,000 RPM, 5/8"-11 Spindle
- 52562 – 9,000 RPM, 5/8"-11 Spindle
- 52563 – 6,000 RPM, 5/8"-11 Spindle
- 52564 – 9,000 RPM, M14 x 2 Spindle
- 52565 – 11,000 RPM, M14 x 2 Spindle
- 52566 – 12,000 RPM, M14 x 2 Spindle
- 52567 – 6,000 RPM, M14 x 2 Spindle



## ! WARNING

Read and understand this tool manual before operating your air tool. Follow all safety rules for the protection of operating personnel as well as adjacent areas. Always operate, inspect and maintain this tool in accordance with the American National Safety Institute (ANSI) Safety Code for Portable Air Tools – B186.1. For additional safety information, refer to Safety Requirements for the Use, Care and Protection of Abrasive Wheels – ANSI B7.1, Code of Federal Regulation – CFR 29 Part 1910, European Committee for Standards (EN) Hand Held Non-Electric Power Tools – Safety Requirements and applicable State and Local Regulations.

## SAFETY LEGEND

	<p><b>! WARNING</b></p> <p>Read and understand tool manual before work starts to reduce risk of injury to operator, visitors, and tool.</p>	<p><b>! WARNING</b></p> <p>Practice safety requirements. Work alert, have proper attire, and do not operate tools under the influence of alcohol or drugs.</p>	
	<p><b>! WARNING</b></p> <p>Eye protection must be worn at all times, eye protection to conform to ANSI Z87.1.</p>	<p><b>! WARNING</b></p> <p>Ear protection to be worn when exposure to sound, exceeds the limits of applicable Federal, State or local statutes, ordinances and/or regulations.</p>	
	<p><b>! WARNING</b></p> <p>Respiratory protection to be used when exposed to contaminants that exceed the applicable threshold limit values required by law.</p>	<p><b>! WARNING</b></p> <p>Air line hazard, pressurized supply lines and flexible hoses can cause serious injury. Do not use damaged, frayed or deteriorated air hoses and fittings.</p>	

### SAFETY INSTRUCTIONS

Carefully Read all instructions before operating or servicing any Dynabrade® Abrasive Power Tool. Products offered by Dynabrade are not to be modified, converted or otherwise altered from the original design without expressed written consent from Dynabrade, Inc.

**Tool Intent:** Right-Angle Sanders are ideal for surface preparation including sanding metal parts and removing rust or paint.

**Do Not Use Tool For Anything Other Than Its Intended Applications.**

**Training:** Proper care, maintenance, and storage of your tools will maximize their performance.

- Employer's Responsibility – Provide right-angle sanders operators with safety instructions and training for safe use of tools and accessories.

**Accessory Selection:**

- Abrasive/accessory RPM (speed) rating MUST be approved for AT LEAST the tool RPM rating.
- Before mounting an accessory, visually inspect for defects. Do not use defective accessories.
- Use only recommended accessories. See back page of manual and Dynabrade catalog.
- Follow tool specifications before choosing size and type of accessory.
- DO NOT mount round abrasive discs that overhang the backing pad by more than 1/4 inch (6mm).
- Only use recommended fittings and air line sizes. Air supply hoses and air hose accessories must have a minimum working pressure rating of 150 PSIG (10 Bars, g) or 150 percent of the maximum pressure produced in the system, whichever is higher. (See tool Machine Specifications table.)

### OPERATING INSTRUCTIONS

**Warning:** Always wear eye protection. Operator of tool is responsible for following: accepted eye, face, respiratory, hearing and body protection.

(continued on next page)

## OPERATING INSTRUCTIONS (continued)

**Caution:** Hand, wrist and arm injury may result from repetitive work, motion and overexposure to vibration.

- Keep hand and clothing away from working end of the air tool.

**Operation:** Be sure that any loose clothing, hair and all jewelry is properly restrained.

- Secure inlet bushing on air tool with a wrench before attempting to install the air fitting to avoid damaging housing assembly.
- BEFORE MOUNTING AN ACCESSORY, after all tool repairs and whenever a sander is issued for use, check tool RPM (speed) with tachometer with air pressure set at 90 PSIG while tool is running. If tool is operating at a higher speed than the RPM marked on the tool housing, or operating improperly, the tool must be serviced and corrected before use.

**Caution:** Tool RPM must never exceed abrasive/accessory RPM rating. Check accessory manufacturer for details on maximum operating speed or special mounting instructions.

- With power source disconnected from air tool, mount recommended accessory into collet assembly.

## SANDING DISC MOUNTING

### Typical Mounting Diagram for Sanding Discs

- With power source disconnected from the air tool.
- Clean spindle and flange mounting surfaces. Inspect for nicks, cuts and sharp edges.
- Install washers (if required) and back-up pad.
- Check back-up pad flatness and runout by rotating spindle and back-up pad together.
- Install abrasive disc over spindle thread.
- Install flange nut with raised boss facing toward abrasive disc and secure flange firmly against the abrasive disc, make certain abrasive disc is centered on spindle and back-up pad with 1/4" max. overhang (see diagram).
- Check for disc firmness by holding the spindle and pulling on the edge of the wheel in the tightening direction.

**Caution:** Over tightening the flange nut can cause damage to the wheel, flanges, and or back-up pad.

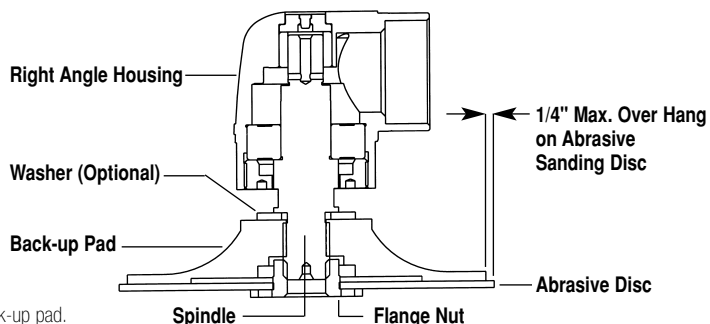

- Connect air tool to power source. Be careful NOT to depress throttle lever in the process. **Do not expose air tool to inlet pressure above 90 PSIG or (6.2 Bars).**

**Caution:** After installing the accessory, before testing or use and/or after reassembling tool, the right-angle sander must be started at a reduced speed to check for good balance. Gradually increase tool speed. DO NOT USE if tool vibration is excessive. Correct cause, and retest to insure safe operation.

- Make sure that work area is uncluttered, and visitors are at a safe range from the tools and debris.
- Air tools are not intended for use in explosive atmospheres and are not insulated for contact with electric power sources.
- Use a vise or clamping device to hold work piece firmly in place.
- Do not apply excessive force on tool or apply "rough" treatment to it.
- Always work with a firm footing, posture and proper lighting.
- Ensure that sparks and debris resulting from work do not create a hazard.
- This tool has rear exhaust. Exhaust may contain lubricants, vane material, bearing grease, and other materials flushed thru the tool

**Warning:** Sanding certain materials can create explosive dust. It is the employers responsibility to notify the user of acceptable dust levels.

- Sanding can cause sparks which can cause fires or explosions. It is the users responsibility to make sure the work area is free of flammable materials.

**Report to your supervisor any condition of the tool, accessories, or operation you consider unsafe.**

## Air System

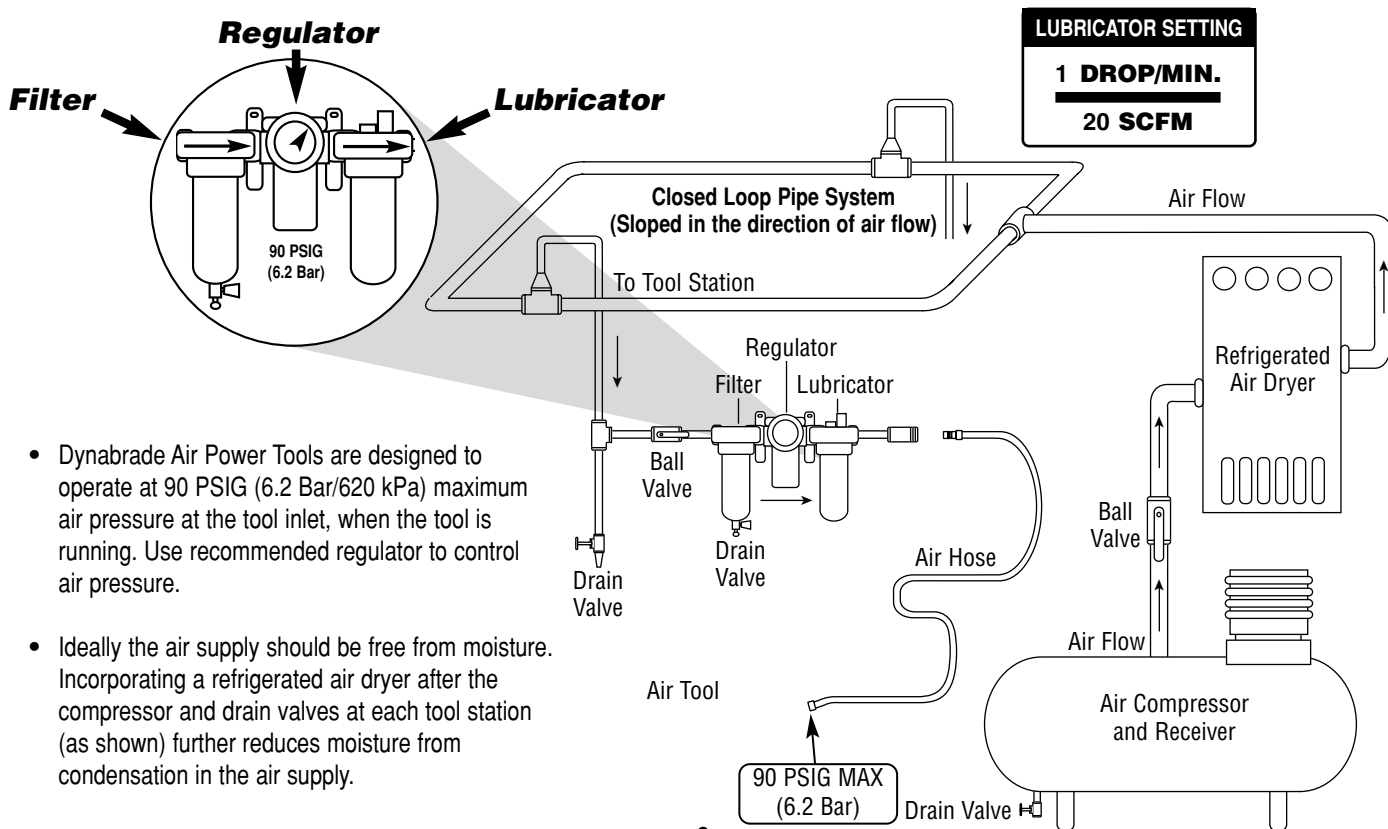

- Dynabrade Air Power Tools are designed to operate at 90 PSIG (6.2 Bar/620 kPa) maximum air pressure at the tool inlet, when the tool is running. Use recommended regulator to control air pressure.
- Ideally the air supply should be free from moisture. Incorporating a refrigerated air dryer after the compressor and drain valves at each tool station (as shown) further reduces moisture from condensation in the air supply.

# Maintenance Instructions

**Important:** A preventative maintenance program is recommended whenever portable power tools are used. The program should include inspection of air supply lines, air line pressure, proper lubrication and repair of tools. Refer to ANSI B186.1 for additional maintenance information.

- Use only genuine Dynabrade replacement parts to insure quality. To order replacement parts, specify **Model#**, **Serial#** and **RPM** of your air tool.
- It is strongly recommended that all Dynabrade rotary vane air tools be used with a Filter-Regulator-Lubricator to minimize the possibility of misuse due to unclean air, wet air or insufficient lubrication. Dynabrade recommends the following: **10681** Air Filter-Regulator-Lubricator (FRL) – Provides accurate air pressure regulation and two stage filtration of water contaminants. Operates 55 SCFM/1,558 LPM @ 90 PSIG with 1/2" NPT female ports.
- Lubricate wick system through the angle gear oil fitting with 2-3 plunges for every 8 hours of use, to achieve maximum gear life. **Important:** Use only the recommended angle gear oil for the wick system. Do not contaminate the wick with any other oil or grease product (order **95848** Gear Oil and **95541** Gun).
- Dynabrade recommends one drop of air lube per minute for each 20 SCFM (example: if the tool specification states 40 SCFM, set the drip rate on the filter-lubricator to 2 drops per minute). Dynabrade Air Lube (P/N **95842**: 1 pt 473 ml) is recommended.

## Routine Preventative Maintenance:

- Check free speed of right-angle sander using a tachometer. This governor controlled right-angle sander should be speed checked every 20 hours of use or weekly, whichever occurs more frequently.
- **DO NOT** disassemble the governor for any reason. Reorder correct speed – governor assembly (See Assembly Breakdown) and recheck free speed of tool with a tachometer.
- Inspect pad backing for excessive wear, nicks, cracks and cuts at the pad edges. Do not use pads that show excessive wear. Check pad backing for concentricity.
- Visually inspect abrasive discs for nicks, cuts, tears at the edges. Abrasive disc with a curved shape indicates improper storage. Do not use abrasives that show these characteristics.
- Mineral spirits are recommended when cleaning the tool and parts. Do not clean tool or parts with any solvents or oils containing acids, esters, ketones, chlorinated hydrocarbons or nitro carbons.
- **DO NOT** clean or maintain tools with chemicals that have a low flash point (example: WD-40®).
- A Motor Tune-Up Kit (P/N **96532**) is available which includes high wear and medium wear motor parts.
- Air tool labels must be kept legible at all times, if not, reorder label(s) and replace. User is responsible for maintaining specification information i.e.: Model #, S/N, and RPM. (See Assembly Breakdown)
- Blow air supply hose out prior to initial use.
- Visually inspect air hoses and fittings for frays, visible damage and signs of deterioration. Replace damaged or worn components.
- Refer to Dynabrade's Warning/Safety Operating Instructions Tag (Reorder No. **95903**) for safety information.

After maintenance is performed on tool, add a few drops of Dynabrade Air Lube (P/N **95842**) to the air line and start the tool a few times to lubricate air motor. Check for excessive tool vibration.

## Handling and Storage:

- Use of tool rests, hangers and/or balancers is recommended.
- Protect tool inlet from debris (see Notice below).
- **DO NOT** carry tool by air hose or near the tool throttle lever.
- Protect abrasive accessories from exposure to water, solvents, high humidity, freezing temperature and extreme temperature changes.
- Store abrasive discs prior to use at 30-50% relative humidity and 60-80° F (15-27° C) to reduce curling.
- Store accessories in protective racks or compartments to prevent damage.

## Machine Specifications

Model Number	Motor HP (W)	Tool RPM	Sanding Disc Dia.	Sound Level	Air Flow Rate SCFM (LPM)	Air Pressure PSIG (Bars)	Spindle Thread	Weight Pound (kg)	Length Inch (mm)	Height Inch (mm)
52560	1 (746)	12,000	4"	78 dB(A)	40 (1,132)	90 (6.2)	3/8"- 24 Male	4.0 (1.8)	11-11/16 (296)	4-1/4 (108)
52561	1 (746)	11,000	4 1/2"	79 dB(A)	41 (1,161)	90 (6.2)	5/8"-11 Male	4.0 (1.8)	11-11/16 (296)	3-3/4 (93)
52562	1 (746)	9,000	5"	80 dB(A)	39 (1,104)	90 (6.2)	5/8"-11 Male	4.0 (1.8)	11-11/16 (296)	3-3/4 (93)
52563	1 (746)	6,000	7"	82 dB(A)	40 (1,132)	90 (6.2)	5/8"-11 Male	4.0 (1.8)	11-11/16 (296)	3-3/4 (93)
52564	1 (746)	9,000	N/A	80 dB(A)	39 (1,104)	90 (6.2)	M14 x 2 Male	4.0 (1.8)	11-11/16 (296)	3-3/4 (93)
52565	1 (746)	11,000	N/A	79 dB(A)	41 (1,161)	90 (6.2)	M14 x 2 Male	4.0 (1.8)	11-11/16 (296)	3-3/4 (93)
52566	1 (746)	12,000	N/A	78 dB(A)	40 (1,132)	90 (6.2)	M14 x 2 Male	4.0 (1.8)	11-11/16 (296)	3-3/4 (93)
52567	1 (746)	6,000	N/A	82 dB(A)	40 (1,132)	90 (6.2)	M14 x 2 Male	4.0 (1.8)	11-11/16 (296)	3-3/4 (93)

Additional Specifications: Air Inlet Thread 3/8" NPT • Hose I.D. Size 3/8" (10mm) • Air Flow Rate Based At Max HP. • Air Pressure 90 PSIG Max

## Notice

All Dynabrade motors use the highest quality parts and metals available and are machined to exacting tolerances. The failure of quality pneumatic motors can most often be traced to an unclean air supply or the lack of lubrication. Air pressure easily forces dirt or water contained in the air supply into motor bearings causing early failure. It often scores the cylinder walls and the rotor blades resulting in limited efficiency and power. Our warranty obligation is contingent upon proper use of our tools and cannot apply to equipment which has been subjected to misuse such as unclean air, wet air or a lack of lubrication during the use of this tool.

## One Year Warranty

Following the reasonable assumption that any inherent defect which might prevail in a product will become apparent to the user within one year from the date of purchase, all equipment of our manufacture is warranted against defects in workmanship and materials under normal use and service. We shall repair or replace at our factory, any equipment or part thereof which shall, within one year after delivery to the original purchaser, indicate upon our examination to have been defective. Our obligation is contingent upon proper use of Dynabrade tools in accordance with factory recommendations, instructions and safety practices. It shall not apply to equipment which has been subject to misuse, negligence, accident or tampering in any way so as to affect its normal performance. Normally wearable parts such as bearings, contact wheels, rotor blades, etc., are not covered under this warranty.

## Index Key

No.	Part #	Description
1	50192	4" Back-up Pad
	51148	4-1/2" Back-up Pad
	51150	5" Back-up Pad
	51151	7" Back-up Pad
2	50963	Retainer
3	53609	Seal
4	53611	Spindle 3/8"-24
	53603	Spindle 5/8"-11
	53606	Spindle M14 x 2
5	97679	Bearing
6	97678	Shim
7	97677	Shim
8	<b>Gear Set</b>	
	53639	6,000 RPM
	53637	9,000, 11,000, 12,000 RPM
9	53608	Wick
10	53600	Right-Angle Housing Assy. Includes the following:
	A	96325 Shell Bearing
	B	53649 Gear Oil Plate
	C	01041 Gear Oil Fitting
11	53163	Side Handle
12	01266	Bearing
13	53635	Pinion Adapter
14	51969	Coupling (2)
15	50902	Coupling Insert
16	53650	Lock Ring
17	53651	Spacer
18	96498	Wave Spring
19	95438	O-Ring
20	53620	Adapter
21	54520	Bearing
22	51951	Shim Pack
23	51922	Front Bearing Plate
24	96441	Pin (2)
25	51927	Spacer
26	51921	Rotor
27	51926	Blade (4/Pkg.)
28	51925	Cylinder
29	51923	Rear Bearing Plate
30	02057	Bearing
31	96445	Pin (2)
32	51924	Gasket
33	<b>Governor Assembly</b>	
	51931	6,000 RPM Models
	51644	9,000 RPM Models
	51959	11,000 RPM Models
	51932	12,000 RPM Models
34	<b>All Housings Include:</b>	
	Warning & Specification Labels	
	20076	Housing - Model 52560
	20077	Housing - Model 52561
	20078	Housing - Model 52562
	20079	Housing - Model 52563
	20072	Housing - Model 52564
	20073	Housing - Model 52565
	20074	Housing - Model 52566
	20071	Housing - Model 52567
35	96444	Pin
36	51949	Safety Lever Assembly
37	51946	Valve Stem Assembly (Incl. 96443 O-Ring)
38	51945	Valve Seat
39	51944	Tip Valve
40	51943	Spring
41	96442	O-Ring
42	51940	Spacer
43	53682	Gasket-Standard
	53687	Gasket-For use with overhose
44	94528	Felt Silencer
45	53686	Muffler Cap
46	94924	Wave Spring
47	53683	Spacer
48	53681	Inlet Bushing (Incl. 2 - 51938 Screens)

## Label Key

No.	Part #	Description
49	00001180	Warning Label
50	00001181	Specification Label

# 1hp Right-Angle Disc Sander Complete Assembly

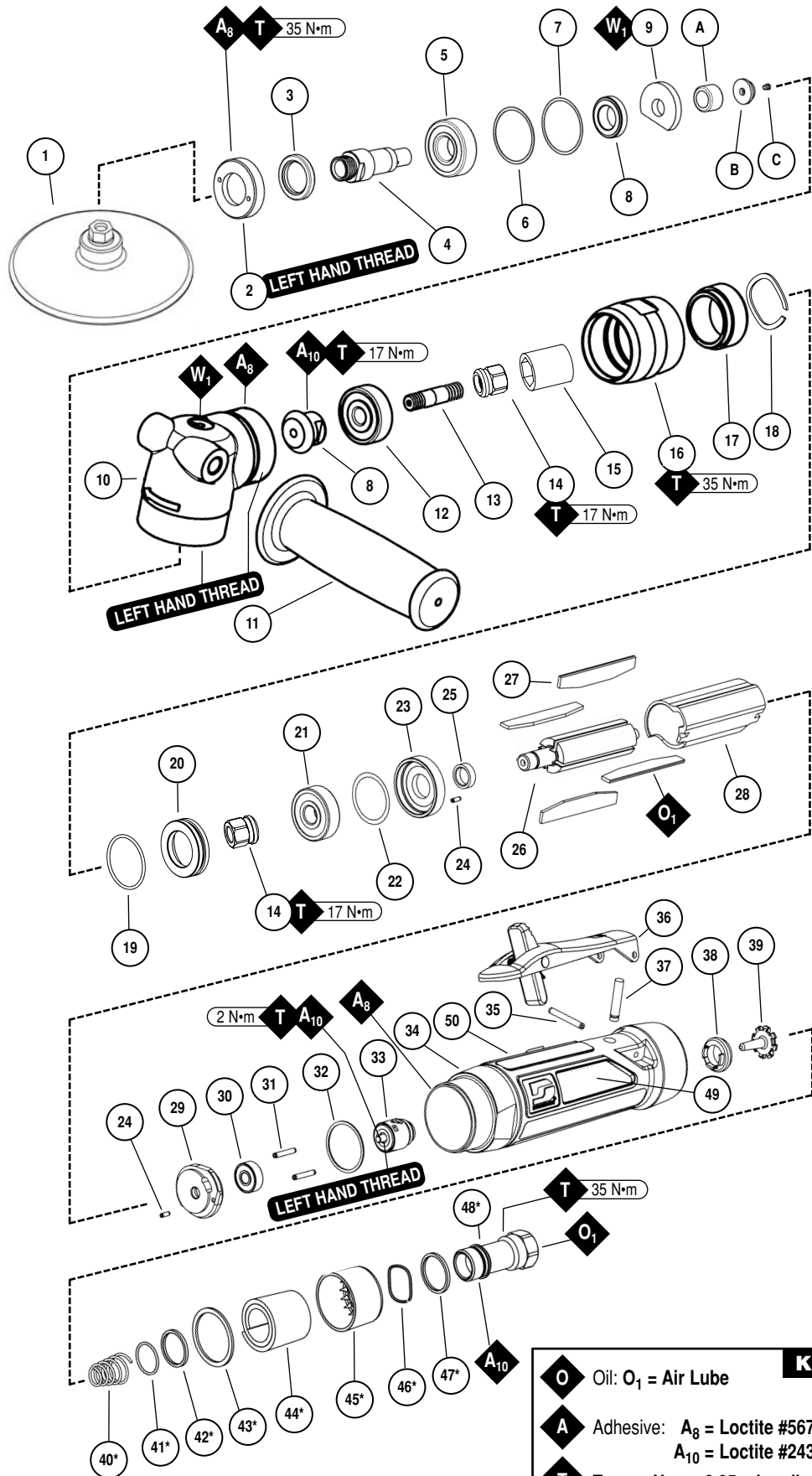

Note: All index numbers with an asterisk are included in P/N 53655 Muffler Assembly.

KEY	
<b>O</b>	Oil: O <sub>1</sub> = Air Lube
<b>A</b>	Adhesive: A <sub>8</sub> = Loctite #567 A <sub>10</sub> = Loctite #243
<b>T</b>	Torque: N·m x 8.85 = In. - lbs.
<b>W</b>	Wicking: W <sub>1</sub> = Gear Oil

# **Disassembly Instructions - 1hp Right-Angle Disc Sander**

**Important:** Manufacturer's warranty is void if tool is disassembled before warranty expires.

**Disconnect tool from power source before tool repair.**

## **Right Angle Head Disassembly:**

1. Remove side handle, abrasive and backup pad.
2. Secure **53600** Right Angle Housing, against both side handle bosses, in a padded vise with spindle facing upward.
3. Using **97782** Pin Wrench (*ordered separately*) or an adjustable pin wrench, remove **50963** Retainer. (**Left Hand Threads**)
4. Remove **53609** Felt Seal from retainer.
5. Pull Spindle and gear assembly from housing.
6. Press spindle through **97679** Bearing and spiral bevel gear.
7. Remove shims and **53608** Wick from right angle housing.
8. Remove **53650** Lock Ring from right angle housing (**Left Hand Threads**) and from motor housing (**Right Hand Threads**).
9. Remove angle head from vise and remove **96325** Bearing by pressing **53649** Gear Oil Plate through housing.
10. Pull pinion gear, bearing and coupler sub-assembly from angle housing.
11. Secure pinion gear wrench flats and remove the **51969** Coupler (twist counterclockwise).
12. Secure **53635** Adapter using **95049** 3/16" Hex Key wrench and remove pinion gear (twist counterclockwise).
13. Press **53635** Adapter through **01266** Bearing.

**Right Angle Head Disassembly Complete.**

## **Motor Disassembly:**

1. Remove **53651** Spacer and **96498** Wave Spring from housing assembly.
2. Pull motor assembly from housing, and remove **53620** Motor Adapter with **95438** O-Ring.
3. Remove governor assembly by using a slotted screwdriver. (**Left Hand Threads**)
4. Using **96209** Repair Clamp (*ordered separately*), secure **51925** Cylinder and place a 1/8" (3mm) drift pin to the base of the terminal thread and press the **51921** Rotor from the **02057** Rear Bearing.
5. Slide **02057** Rear Bearing from **51923** Rear Bearing Plate.
6. Remove **51925** Cylinder and **51926** Blades.
7. Secure **51921** Rotor in padded vise and remove **51969** Coupler (twist counterclockwise).
8. Slide **51922** Front Bearing Plate and **51927** Rotor Spacer from **51921** Rotor.
9. Slide **54520** Bearing and shims from **51922** Front Bearing Plate.

**Motor Disassembly Complete.**

## **Housing Disassembly:**

1. Secure housing using **51989** Repair Collar (*see back cover for Optional Accessories*).
2. Remove inlet bushing with muffler assembly (twist counterclockwise).
3. Remove **53682** Gasket, **51943** Spring, **96442** O-ring, **51940** Spacer, **94528** Felt Silencer, **53686** Muffler Cap, **94924** Wave Spring and **53683** Spacer from **53681** Inlet Bushing.
4. Remove **51944** Tip Valve and **51945** Valve Seat.
5. Remove housing and **51989** Repair Collar and lay collar on bench with flange facing down so it is supporting throttle lever. Place a 3/32" (2.4mm) drift pin on **96444** Pin and tap pin thru housing.
6. Remove **51946** Valve Stem Assembly.
7. Remove **96443** O-Ring from **51946** Valve Stem Assembly.

**Housing Disassembly Complete.**

# **Assembly Instructions - 1hp Right-Angle Disc Sander**

## **Motor Assembly:**

**Important:** Be sure parts are clean and in good repair before assembling. Follow lubrication and torque specifications.

1. Place **51921** Rotor into a padded vise with male thread facing upwards.
2. Slip **51927** Rotor Spacer over rotor shaft and down against rotor body face.
3. Press **96441** Coiled Pin into **51922** Front Bearing Plate. Make certain, coiled pin does not protrude beyond internal bearing surface.
4. Place a .002" shim into the base of **51922** Front Bearing Plate as an initial spacing and slide **54520** Bearing to the front plate base.  
**Note:** **51951** Shim Pack contains /001" and .002" shims.
5. Slip bearing/bearing plate assembly onto rotor. Add one drop of Loctite® #243 (or equiv.) to **51921** Rotor 3/8"-24 male thread and screw **51969** Coupler into place (Torque to 17 N•m 150 lb.-in.).
6. Check clearance between rotor and front bearing plate by using a .001" feeler gauge. Clearance should be between .001" – .0015". Adjust clearance by repeating steps 4 and 5 with different shims if necessary.
7. Once proper rotor gap clearance is achieved, install well lubricated **51926** Blades (4) into rotor slots. Dynabrade recommends lubricating blades with **95842** Air Lube.
8. Install **51925** Cylinder over rotor and front plate raised boss. Align coiled pin on front plate to cylinder slot.
9. Press **96441** Coiled Pin into blind hole on **51923** Rear Bearing Plate. Press (2) **96445** Coiled Pins into the back side of rear bearing plate.
10. Peel backing off **51924** Gasket and apply it firmly in place onto **51923** Rear Bearing Plate.
11. Place **51923** Rear Bearing Plate over rotor mandrel and insert raised boss on rear bearing plate into cylinder diameter, while inserting short coiled pin into cylinder slot. Be sure inlet slot on rear bearing plate line up with inlet slot on cylinder. To correct alignment Flip cylinder end to end and repeat steps 8 & 9 for correct assembly.

(continued on next page)

## Assembly Instructions - (Continued)

**Important: Manufacturer's warranty is void if tool is disassembled before warranty expires.**

**Please refer to parts breakdown for part identification.**

- Using **96243** Bearing Press Tool (*ordered separately*) press **02057** Bearing onto rotor and into **51923** Rear Bearing Plate hole until it is seated.  
**Important:** Cylinder must fit snug between bearing plates. If too tight, rotor will not turn freely. Rotor must be lightly tapped at press fit end until rotor spins freely while still maintaining a snug fit. A loose fit will not achieve the proper preload on motor. While pressing **02057** Bearing, make certain to contact inner race of bearing.
- Add one drop of Loctite® #243 (or equiv.) to governor assembly male thread and screw governor assembly into place (**Left Hand Threads**) with a slotted screwdriver. Torque to 2 N•m (18 lb. - in.)
- Install motor assembly into housing, making sure motor drops all the way into housing. **Note:** Align both **96445** Coiled Pins to slots in insert and against **51924** Gasket.
- Install **95438** O-Ring onto **53620** Adapter and slide adapter into housing and over **54520** Bearing.
- Place **96498** Wave Washer onto **53620** Adapter.
- Place **50902** Coupling Insert into **51969** Coupling. Make certain radii aligns with radii in coupling base, to correct alignment remove insert and rotate 90°.

**Motor Assembly Complete.**

### Right Angle Head Assembly:

- Press **01041** Grease Fitting into **53649** Gear Oil Plate and insert sub-assembly into right angle housing.
- Press **96325** Bearing into housing until it is firmly seated against **53649** Gear Oil Plate. **Important:** While pressing **96325** Bearing, make certain press tool is similar in size to the outside diameter of the bearing.
- Add one drop of Loctite® #243 (or equiv.) to male thread of **53635** Adapter and tighten pinion using a **95049** 3/16" Hex Key wrench and the pinion wrench flats. Torque to 17 N•m (150 lb.- in.)
- Using **96244** Bearing Press Tool (*ordered separately*) press **53635** Adapter into **01266** Bearing. **Important:** While pressing **01266** Bearing, make certain to contact inner race of bearing only.
- Add one drop of Loctite® #243 (or equiv.) to male thread of adapter and tighten **51969** Coupler using wrench flats. Torque to 17 N•m (150 lb.- in.)
- Insert sub-assembly into male threaded end of **53600** Right Angle Housing.
- Apply a small amount of Loctite® #567 (or equiv.) to **53600** Right Angle Housing thread, and install **53650** Lock Ring (**Left Hand Threads**).
- Insert **53651** Spacer, with long length first, into **53650** Lock Ring and up against **01266** Bearing.
- Apply a small amount of loctite® #567 (or equiv.) to male thread of motor housing.
- Align **50902** Coupling Insert into **51969** Coupling in R/A head assembly. Make certain insert radii aligns with radii in coupling base, to correct alignment remove insert and rotate 90°.
- Thread motor housing into **53650** Lock Ring (twist clockwise).
- Secure **53600** Right Angle Housing, against both side handle bosses, in a padded vise.
- Rotate motor housing and **53650** Lock Ring until throttle lever is located between the 9-11 o'clock position. Throttle lever in this position safe guards against accidental start ups of the tool. Torque lock ring to 35 N•m (310 lb.- in.)
- Place well lubricated **53608** Wick against **96325** Bearing with flat edge towards pinion gear. (Wick must be completely saturated with Dynabrade **95848** Gear Oil before installation). **Note:** Do not contaminate wick with any other oil or grease product.
- Press **97679** Bearing onto spindle and against shoulder. **Important:** While pressing **97679** Bearing, make certain to contact inner race of bearing only.
- Press gear, with teeth facing away from bearing, onto spindle and against **97679** Bearing inner race.
- Insert spindle assembly into **53600** Right Angle Housing until **97679** Bearing contacts housing shoulder.
- Rotate Spindle while pressing down into housing to check for gear alignment and backlash. Install shims as required (minimum backlash is recommended for maximum gear life. Make certain there is clearance throughout 360° revolution).
- Slide **53609** Felt Seal into **50963** Retainer.
- Apply a small amount of Loctite® #567 (or equiv.) to **50963** Retainer thread. Install retainer into **53600** Right Angle Housing (Left Hand Threads).
- Using **97782** Pin Wrench (*ordered separately*) or an adjustable pin wrench, torque retainer to 35 N•m (310 lb.- in.).

### Housing Assembly:

- Secure housing using **51989** Repair Collar (*see back cover for Optional Accessories*) with inlet facing upward.
- Slide **96443** O-Ring onto **51946** Valve Stem and slide sub-assembly until o-ring passes through housing hole. Make certain valve stem assembly slides freely after the o-ring passes through the hole.
- Install **51945** Valve Seat by aligning 3 male prongs with three deep slots on insert. Make certain valve seat is pressed flat against base of pocket.  
**Note:** Add a few drops of Dynabrade Air Lube (P/N **95842**) to pocket walls before inserting **51945** Valve Seat.
- Install **51944** Tip Valve as shown.
- Pre-assemble muffler, slide **53683** Spacer over **53681** Inlet bushing and up against the hex head base. Slide **94924** Wave Spring over **53681** Inlet Bushing and up against spacer. Pre roll **94528** Felt and install it in **53686** Muffler Cap, support felt in felt/muffler cap assembly and slide **53681** Inlet Bushing thru the inside until the muffler cap assembly seats against **94924** Wave Spring. Flare the felt and place **51940** Spacer over male tread, and set **96442** O-Ring into groove at the base of thread, return felt to unflared form. Slide **51943** Spring into bushing end up to the two **51938** Screens.
- Place **53682** Gasket over felt silencer and against **53686** Muffler Cap.
- Apply one drop of Loctite® #243 (or equiv.) to **53681** Inlet Bushing thread.
- Align small inside diameter of **51943** Spring to cone point on **51944** Tip Valve and thread Inlet Bushing and sub-assembly into place. Torque bushing to 35 N•m (310 lb.- in.).
- Remove housing from **51989** Repair Collar and place repair collar onto the bench top with the part number identifier against the bench. Align the throttle lever holes to housing pinhole and rest the housing and throttle lever onto the legs of the repair collar. Press **96444** Coiled Pin into lever hole and center into housing.

**Tool Assembly Complete. Please allow 30 minutes for adhesives to cure before operating tool.**

**Important:** Before operating, place 2-3 drops of Dynabrade Air Lube (P/N **95842**) directly into inlet with throttle lever depressed. Operate tool for 30 seconds to allow air lube to properly lubricate internal motor components. Motor should now be tested for proper operation at 90 PSIG max. If tool operates at a higher RPM than marked on the tool or if vibration and sound levels seem abnormal, the tool should be serviced to correct the cause before use.

# Preventative Maintenance Schedule

For All 1hp Right-Angle Disc Sanders

This service chart is published as a guide to expectant life of component parts. The replacement levels are based on average tool usage over one year. Dynabrade Inc. considers one year usage to be 1,000 hours or 50% of a man year. Parts included in motor tune-up kit are identified by High Wear and Medium Wear items.

## Parts Common to all Models:

LEGEND	
<b>T</b>	Part included in 96532 Tune-up Kit
<b>X</b>	Type of wear, no other comments apply.
<b>L</b>	Easily lost. Care during assembly/disassembly.
<b>D</b>	Easily damaged during assembly/disassembly.
<b>R1</b>	Replace each time tool is disassembled.
<b>R2</b>	Replace each second time tool is disassembled.



### 96532 – 1 Hp. Motor Tune-Up Kit

- Tune-Up Kit includes high wear and medium wear motor parts.

Index #	Part Number	Description	Number Required	High Wear 100%	Medium Wear 70%	Low Wear 30%	Non-Wear 10%
1	See Pg.4	Back-up Pad	1				X
2	50963	Retainer	1				X
3	53609	Seal	1	R2			
4	See Pg.4	Spindle	1				X
5	97679	Bearing	1		X		
6	97678	Shim	1				X
7	97677	Shim	1				X
8	See Pg.4	Gear Set	1			X	
9	53608	Wick	1		X		
10	53600	Right-Angle Housing Assy.	1				X
A	96325	Shell Bearing	1		X		
B	53649	Gear Oil Plate	1				X
C	01041	Gear Oil Fitting	1				X
11	53163	Side Handle	1				X
12	01266	Bearing	1		X		
13	53635	Pinion Adapter	1				X
14	51969	Coupling	2				X
15	50902	Coupling Insert	1			X	
16	53650	Lock Ring	1				X
17	53651	Spacer	1				X
18	96498	Wave Spring	1		T, L		
19	95438	O-Ring	1				T, X
20	53620	Adapter	1				X
21	54520	Bearing	1		T, X		
22	51951	Shim Pack	1		T, L		
23	51922	Front Bearing Plate	1			X	
24	96441	Pin	2			X	
25	51927	Spacer	1		T, X		
26	51921	Rotor	1			X	
27	51926	Blade (4/pkg.)	1	T, X			
28	51925	Cylinder	1			X	
29	51923	Rear Bearing Plate	1			X	
30	02057	Bearing	1		T, X		
31	96445	Pin	2			X	
32	51924	Gasket	1		T, X		
33	See Pg.4	Governor Assembly	1				X
34	See Pg.4	Housing	1				X
35	96444	Pin	1		T, L		
36	51949	Safety Lever Assembly	1			X	
37	51946	Valve Stem Assembly (Includes 96443 O-Ring)	1		T, X		
38	51945	Valve Seat	1				X
39	51944	Tip Valve	1		T, X		
40	51943	Spring	1				X
41	96442	O-Ring	1		T, L		
42	51940	Spacer	1				X
43	53682	Gasket	1				
44	94528	Felt Silencer	1	T, R1			
45	53686	Muffler Cap	1				X
46	94924	Wave Spring	1				X
47	53683	Spacer	1				X
48	53681	Inlet Bushing (Incl. 2 – 51938 Screens)	1				X

Note: Please refer to page 4 of tool manual for specific part number.

# Optional Accessories



## Dynamswivel®

- Swivels 360° AT TWO PIVOT POINTS allowing the air hose to drop directly to the floor while providing superb tool handling.  
95461 – 3/8" NPT.

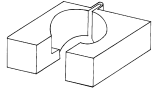

## 51989 Repair Collar

- Specially designed collar for use in vise to prevent damage to valve body of tool during disassembly/assembly.



## Dynabrade Air Lube

- Formulated for pneumatic equipment.
- Absorbs up to 10% of its weight in water.
- Prevents rust and formation of sludge.
- Keeps pneumatic tools operating longer with greater power and less down time.  
95842: 1 pt. (473 ml)  
95843: 1 gal. (3.8 L)



## 96005 Male Plug

- Provides up to twice the air flow compared to standard plug design.
- Plug has "ported" design to prevent "starving" of the air tool.



## Dynabrade Angle Gear Oil

- Specifically formulated to saturate wick system in right angle gear head.  
95848: 2 oz. tube  
95849: 10 oz. tube  
95541: Push-Type Gear Oil Gun

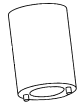

## 97782 Retainer Repair Tool

- Tool has a 3/8 in. square socket for use with 3/8 in. drive; breaker bar, ratchet head, or torque wrenches.



## 53134 Vibration Reduction Handle

- Increases operators comfort when using unbalanced grinding wheels.



## 96532 Motor Tune-Up Kit

- Includes assorted parts to help maintain and repair motor.

## 01902 Drop-In Motor

- Allows quick and easy replacement. No motor adjustments needed.



## 53621 Over Hose Assembly

- Over Hose Assembly directs exhaust away from operator.



## Composite-Style Coupler

- Lightweight 1.4 oz. (.05 Kg), non-marring composite material.
- Easy connect/disconnect by single push-button action.
- Shock-proof, low-vibration, crush-resistant.  
94960: 1/4" Female NPT  
94980: 1/4" Male NPT

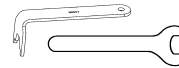

- 95281 – 19mm open-end wrench.  
96507 – Pin wrench.



## 30335 Air Supply Hose

- 3/8 in. I.D. x 60 in. Wide air supply hose, includes: 3/8 in. NPT male and female threaded fittings.



## Bearing Press Tool

- Used to install bearings.  
96243: For installing 02057 Bearing.  
96244: For installing 01266 Bearing.



## 96209 Motor Repair Clamp

- Specially designed clamp to secure motor cylinder before disassembly.

## Reference Contact Information

1. **American National Standards Institute – ANSI**  
25 West 43<sup>rd</sup> Street  
Forth Floor  
New York, NY 10036  
Tel: 1 (212) 642-4900  
Fax: 1 (212) 398-0023

2. **Government Printing Office – GPO**  
Superintendent of Documents  
Attn. New Orders  
P.O. Box 371954  
Pittsburgh, PA 15250-7954  
Tel: 1 (202) 512-1803

3. **European Committee for Standardization**  
Rue de Stassart 36  
B - 1050 Brussels, Belgium

Visit Our Web Site: [www.dynabrade.com](http://www.dynabrade.com)

Email: [Customer.Service@Dynabrade.com](mailto:Customer.Service@Dynabrade.com)



**DYNABRADE, INC.,** 8989 Sheridan Drive • Clarence, NY 14031-1490 • Phone: (716) 631-0100 • Fax: 716-631-2073 • International Fax: 716-631-2524  
**DYNABRADE EUROPE S.à.r.l.,** Zone Artisanale • L-5485 Wormeldange—Haut, Luxembourg • Telephone: 352 76 84 94 1 • Fax: 352 76 84 95 1

© DYNABRADE, INC., 2008

PRINTED IN USA