

Model:

- 52224 - 6mm Collet, 15,000 RPM
- 52225 - 6mm Collet, 18,000 RPM
- 52226 - 6mm Collet, 20,000 RPM
- 52227 - 6mm Collet, 20,000 RPM*
- 52288 - 1/4" Collet, 15,000 RPM
- 52289 - 1/4" Collet, 18,000 RPM
- 52290 - 1/4" Collet, 20,000 RPM
- 52291 - 1/4" Collet, 20,000 RPM*

(*Includes 53163 Side Handle)

Parts Page Reorder No. PD02-19

Effective April, 2002

Supersedes PD96-72

.7Hp/7°/Short Shank/Front Exhaust Die Grinder

Machine and Motor Parts

! WARNING

Always operate, inspect and maintain this tool in accordance with the Safety Code for portable air tools (ANSI B186.1) and any other applicable safety codes and regulations. Please refer to Dynabrade's Warning/Safety Operating Instructions for more complete safety information.

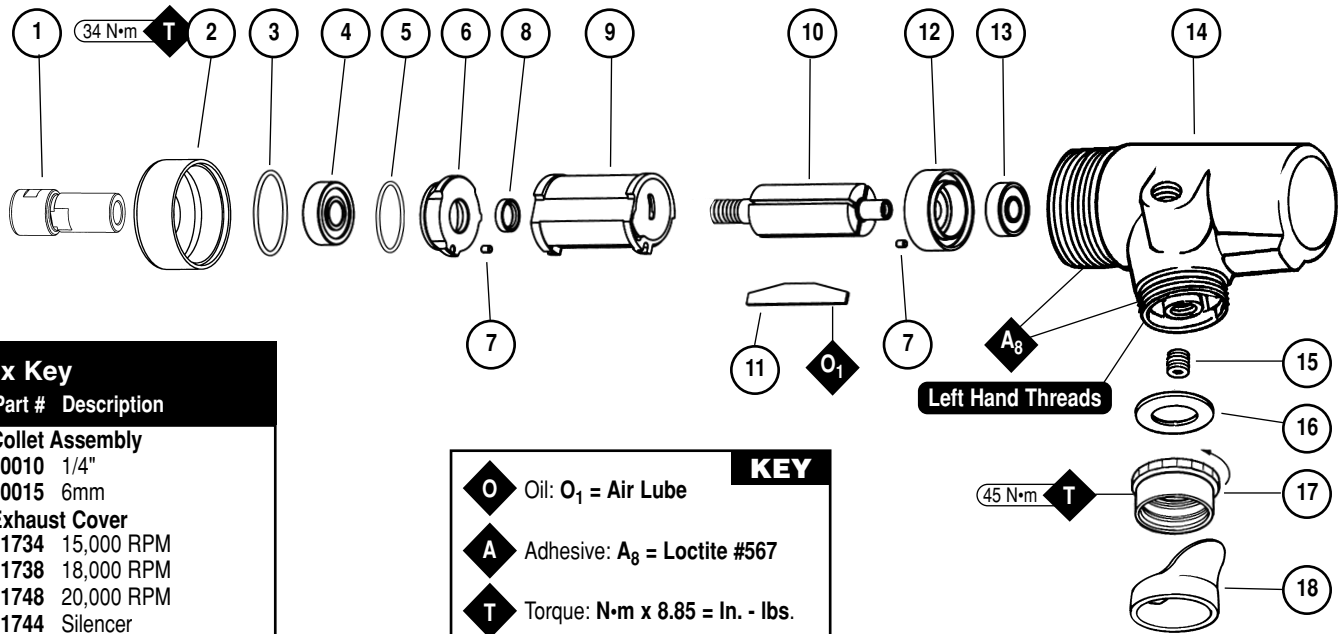

Index Key

No.	Part #	Description
1	Collet Assembly	
	50010	1/4"
	50015	6mm
2	Exhaust Cover	
	01734	15,000 RPM
	01738	18,000 RPM
	01748	20,000 RPM
3	01744	Silencer
4	01007	Bearing
5	01121	Shim (3/pkg.)
6	01008	Plate
7	50767	Guide Pin (2)
8	01010	Spacer
9	01028	Cylinder
10	55021	Rotor
11	01185	Blade (4/Pkg.)
12	01743	Bearing Plate
13	02649	Bearing
14	01739	Motor Housing
15	01437	Plug
16	01548	Gasket
17	01461	Lock Nut
18	01558	Collar
19	01448	Throttle Lever
	01462	Safety Throttle Lever
20	12132	Pin
21	95558	Retaining Ring
22	Housing (See Chart)	
23	01449	Valve Stem
24	95730	O-Ring
25	01024	O-Ring
26	01469	Speed Regulator Assy.
27	01464	Seal
28	01472	Tip Valve
29	01468	Spring
30	01494	Inlet Bushing
31	50033	Hanger

KEY

- Oil: O₁ = Air Lube
- Adhesive: A₈ = Loctite #567
- Torque: N·m x 8.85 = In. - lbs.

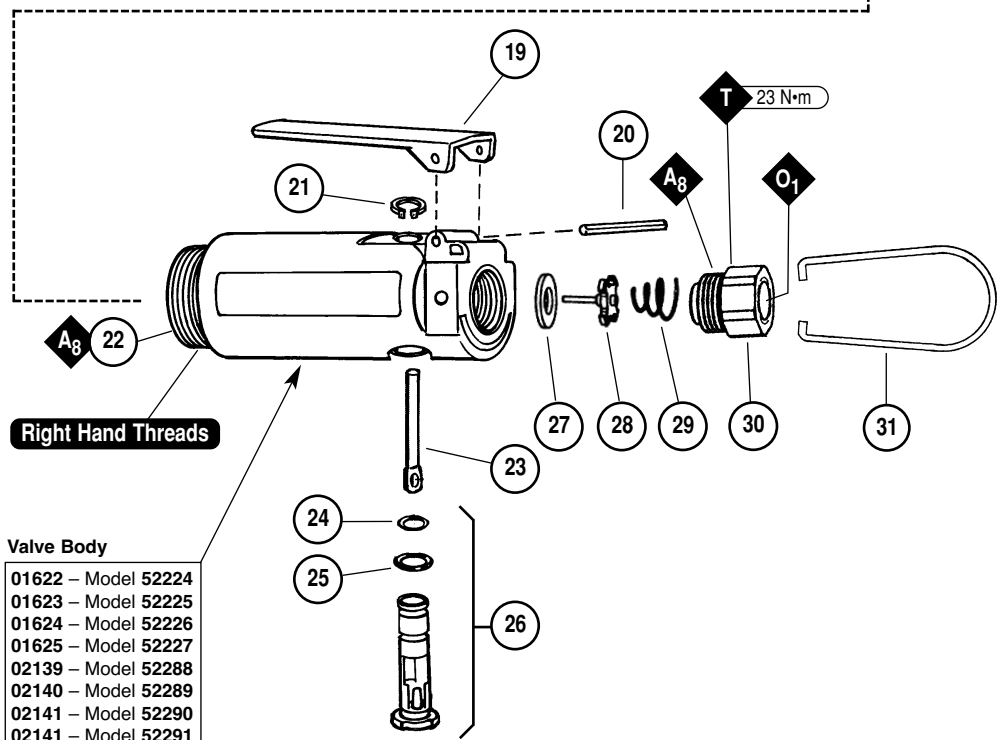

See inside for Important Operating, Maintenance and Safety Instructions.

Important Operating, Maintenance and Safety Instructions

Carefully read all instructions before operating or servicing any Dynabrade® Abrasive Power Tool.

Warning: Hand, wrist and arm injury may result from repetitive work motion and overexposure to vibration.

Important: All Dynabrade rotary vane air tools must be used with a Filter-Regulator-Lubricator to maintain all warranties.

Operating Instructions:

Warning: Eye, face, respiratory, sound, and body protection must be worn while operating power tools. Failure to do so may result in serious injury or death. Follow safety procedures posted in workplace.

1. With power source disconnected from tool, securely fasten abrasive/accessory on tool.
2. Install air fitting into inlet bushing of tool. **Important:** Secure inlet bushing of tool with a wrench before attempting to install the air fitting to avoid damaging valve body housing.
3. Connect power source to tool. Be careful **not** to depress throttle lever in the process.
4. Check tool speed with tachometer. If tool is operating at a higher speed than the RPM marked on the tool or operating improperly, the tool should be serviced to correct the cause before use.

Maintenance Instructions:

1. Check tool speed regularly with a tachometer. If tool is operating at a higher speed than the RPM marked on the tool, the tool should be serviced to correct the cause before use.
2. Some silencers on air tools may clog with use. Clean and replace as required.
3. All Dynabrade rotary vane air motors should be lubricated. Dynabrade recommends one drop of air lube per minute for each 10 SCFM (example: if the tool specification states 40 SCFM, set the drip rate of your filter-lubricator at 4 drops per minute). Dynabrade Air Lube (P/N 95842: 1 pt. 473 ml.) is recommended.
4. It is strongly recommended that all Dynabrade rotary vane air tools be used with a Filter-Regulator-Lubricator to minimize the possibility of misuse due to unclean air, wet air or insufficient lubrication. Dynabrade recommends the following: **11405** Air Line Filter-Regulator-Lubricator — Provides accurate air pressure regulation, two-stage filtration of water contaminants and micro-mist lubrication of pneumatic components. Operates 40 SCFM @ 100 PSIG has 3/8" NPT female ports.
5. Use only genuine Dynabrade replacement parts. To reorder replacement parts, please specify the **Model #**, **Serial #** and **RPM** of your machine.
6. A Motor Tune-Up Kit (P/N 96045) is available which includes assorted parts to help maintain motor in peak operating condition.
7. Mineral spirits are recommended when cleaning the tool and parts. Do not clean tool or parts with any solvents or oils containing acids, esters, ketones, chlorinated hydrocarbons or nitro carbons.

Safety Instructions:

Products offered by Dynabrade should not be converted or otherwise altered from original design without expressed written consent from Dynabrade, Inc.



- **Important:** User of tool is responsible for following accepted safety codes such as those published by the American National Standards Institute (ANSI).
- Operate machine for one minute before application to workpiece to determine if machine is working properly and safely before work begins.
- Always disconnect power supply before changing abrasive/accessory or making machine adjustments.
- Inspect abrasives/accessories for damage or defects prior to installation on tools.
- Please refer to Dynabrade's Warning/Safety Operating Instructions Tag (Reorder No. 95903) for more complete safety information.
- **Warning:** Hand, wrist and arm injury may result from repetitive work, motion and overexposure to vibration.

Notice

All Dynabrade motors use the highest quality parts and metals available and are machined to exacting tolerances. The failure of quality pneumatic motors can most often be traced to an unclean air supply or the lack of lubrication. Air pressure easily forces dirt or water contained in the air supply into motor bearings causing early failure. It often scores the cylinder walls and the rotor blades resulting in limited efficiency and power. Our warranty obligation is contingent upon proper use of our tools and cannot apply to equipment which has been subjected to misuse such as unclean air, wet air or a lack of lubrication during the use of this tool.

One Year Warranty

Following the reasonable assumption that any inherent defect which might prevail in a product will become apparent to the user within one year from the date of purchase, all equipment of our manufacture is warranted against defects in workmanship and materials under normal use and service. We shall repair or replace at our factory, any equipment or part thereof which shall, within one year after delivery to the original purchaser, indicate upon our examination to have been defective. Our obligation is contingent upon proper use of Dynabrade tools in accordance with factory recommendations, instructions and safety practices. It shall not apply to equipment which has been subject to misuse, negligence, accident or tampering in any way so as to affect its normal performance. Normally wearable parts such as bearings, contact wheels, rotor blades, etc., are not covered under this warranty.

Models	Motor HP (W)	Motor RPM	Sound Level	Maximum Air Flow CFM/SCFM (LPM)	Air Pressure PSIG (Bars)	Spindle Thread	Weight Pound (kg)	Length Inch (mm)	Height Inch (mm)
All 15,000 RPM	.7 (522)	15,000	85 dBA	4/32 (906)	90 (6.2)	3/8"-24 male	1.7 (.8)	6 (152)	5-1/2 (140)
All 18,000 RPM	.7 (522)	18,000	87 dBA	5/35 (991)	90 (6.2)	3/8"-24 male	1.7 (.8)	6 (152)	5-1/2 (140)
All 20,000 RPM	.7 (522)	20,000	84 dBA	5/36 (1,020)	90 (6.2)	3/8"-24 male	1.7 (.8)	6 (152)	5-1/2 (140)

Additional Specifications: Air Inlet Thread 1/4" NPT • Hose Size 3/8" (10mm)

Disassembly/Assembly Instructions — .7Hp/7°/Front Exhaust Die Grinder

Please refer to page 1 for part identification.

Important: Manufacturers warranty is void if tool is disassembled before warranty expires.

To Disassemble:

1. Secure air tool in vise using **52996** Repair Collar or padded jaws.
2. Remove collet cap and insert.
3. With a 1-1/2" open-end wrench, remove exhaust cover by turning counter-clockwise.
4. Pull motor assembly from housing.
5. Reposition motor housing in vise so inlet bushing is facing upwards.
6. Unscrew **01494** Inlet Bushing turning counter-clockwise.
7. Using needle nose pliers, remove **01448** Spring, **01472** Tip Valve and **01464** Seal.
8. Resecure housing in vise so throttle lever and **12132** Pin are accessible.
9. Using a 2.5mm diameter drift pin and a hammer, tap **12132** Pin out from housing and remove throttle lever.
10. Remove **95558** Retaining Ring and push **01469** Speed Regulator from Housing.

Optional: To disassemble valve body from motor housing, peel back **01558** Collar to expose **01461** Lock Nut. Unscrew lock nut/valve body from housing (left hand threads).

Motor Disassembly:

1. Press rotor from **01743** Rear Bearing Plate. Press **02649** Bearing from bearing plate.
2. Remove **01008** Front Bearing Plate, cylinder, blades (4) and **01010** Spacer from rotor. **Note:** **01007** Bearing, **01008** Front Bearing Plate and **01010** Spacer are a slip fit onto rotor.
3. Remove **50011** Collet Body from rotor shaft by inserting 3/16" hex wrench through collet body into rotor shaft. Twist collet body from shaft.

Motor Disassembly Complete.

Motor Assembly: (Be sure parts are clean and in good repair before assembling.)

1. Place rotor in padded vise with threaded spindle facing upwards.
2. Slip **01010** Spacer onto rotor.
3. Place a .002" shim into **01008** Front Bearing Plate as an initial spacing (**Note:** **01121** Shim Pack contains .001" and .002" shims) and slip **01007** Bearing into plate.
4. Install Bearing/Bearing Plate assembly onto rotor.
5. Tighten collet body onto rotor (torque to 150 in. lbs.).
6. Check clearance between rotor and bearing plate by using a .001" feeler gauge. Clearance should be at .001" to .0015". Adjust clearance by repeating steps 1-5 with different shim if necessary.
7. Once proper rotor/gap clearance is achieved, install well lubricated **01185** Blades (4) into rotor slots. Dynabrade air lube P/N **95842** is recommended for lubrication.
8. Install cylinder over rotor. Be sure air inlet area of cylinder line up with air inlet holes in the rear bearing plate.
9. Press **02649** Rear Bearing into **01743** Rear Bearing Plate. Press bearing/bearing plate assembly onto rotor. Be sure that pin and air inlet holes line-up with pin slot and air inlet area in cylinder. **Important:** Fit must be snug between bearing plates and cylinder. If too tight, rotor will not turn freely. Rotor must then be lightly tapped at press fit end so it will turn freely while still maintaining a snug fit. A loose fit will not achieve the proper preload of motor bearings.
10. Secure motor housing in padded vise so motor cavity faces upwards.
11. Install motor assembly into housing. Be sure motor drops all the way into housing.
12. Insert **01744** Silencer into exhaust cover and install onto motor housing (torque 300 in. lbs.).
13. Motor adjustment must now be checked. With motor housing still mounted in vise, pull end of rotor and twist (10-15 lbs. force), rotor should turn freely without drag. If drag or rub is felt, then increase preload or remove shim. Also, push end of rotor and twist (10-15 lbs. force), rotor should turn freely without drag. If drag or rub is felt, then deload or add shim.

Valve Stem/Body Assembly:

1. Insert **01469** Speed Regulator Assembly into valve body. Secure with **95558** Retaining Ring.
2. Secure valve body in vise using **52996** Repair Collar or padded jaws with air inlet facing upwards and throttle lever accessible.
3. Insert **01464** Seal into housing.
4. Line-up the hole in the **01449** Valve Stem with the hole in the housing (looking past brass bushing). Using needle nose pliers, insert **01472** Tip Valve so that the metal pin passes through the hole in the valve stem.
5. Install **01468** Spring (small end first).
6. Apply a small amount of #567 Loctite (or equivalent) to threads of **01494** Inlet Bushing and install into valve body (torque 34.0 N•m 300 lbs. in.).
7. Install throttle lever and **12132** Pin. Remove valve body from vise.

Tool Assembly Complete. Please allow 30 minutes for adhesives to cure before operating tool.

Important: Motor should now be tested for proper operation at 90 PSIG. If motor does not operate properly or operates at a higher RPM than marked on the tool, the tool should be serviced to correct the cause before use.

Note: Throttle lever is preset at the factory at an 11:00 o'clock position.

Loctite is a registered trademark of the Loctite Corp.

Optional Accessories



Dynaswivel®

Swivels 360° at two locations which allows an air hose to drop straight to the floor, no matter how the tool is held.

- 94300 1/4" NPT.



96045 Motor Tune-Up Kit

- Includes assorted parts to help maintain and repair motor.



Collet Inserts

- 50065 – 1/8"
- 50013 – 1/4"
- 50014 – 3/8"
- 50016 – 6 mm
- 50039 – 8 mm

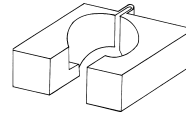

52296 Repair Collar

- Specially designed collar for use in vise to prevent damage to valve body housing during disassembly/assembly.

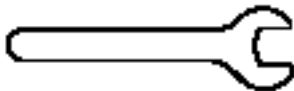

Open-End Wrenches

- 95262 – 14mm open-end.
- 95281 – 19mm open-end.



53163 Side Handle

- Improved ergonomic feel with grip-traction to reduce hand fatigue.
- 5/16"-18 Thread



Dynabrade Air Lube

- Formulated for pneumatic equipment.
- Absorbs up to 10% of its weight in water.
- Prevents rust and formation of sludge.
- Keeps pneumatic tools operating longer with greater power and less down time.

95842: 1 pt. (473 ml)

95843: 1 gal. (3.8 L)

Visit Our Web Site: www.dynabrade.com

Email: Customer.Service@Dynabrade.com



DYNABRADE, INC., 8989 Sheridan Drive • Clarence, New York 14031-1490 • Telephone: (716) 631-0100 • Fax: 716-631-2073 • International Fax: 71-231-2524
DYNABRADE EUROPE s.a.r.l., Zone Artisanale • L-5485 Wormeldange—Haut, Luxembourg • Telephone: 352 76 84 94 1 • Fax: 352 76 84 95 1

© DYNABRADE, INC., 2004

PRINTED IN USA

PD02.19_Rev.1_03/04