

.5Hp/Straight-Line/Front Exhaust Dynastraight® Flapper

Model:
51130 – 18,000 RPM

Air Machine and Motor Parts

! WARNING

Always operate, inspect and maintain this tool in accordance with the Safety Code for portable air tools (ANSI B186.1) and any other applicable safety codes and regulations. Please refer to Dynabrade's Warning/Safety Operating Instructions for more complete safety information.

Index Key

| No. | Part # | Description |
|-----|--------|-----------------------|
| 1 | 51029 | Flap Wheel Adapter |
| 2 | 53175 | Insulator Collar |
| 3 | 04102 | Lock Ring |
| 4 | 04078 | Felt Silencer |
| 5 | 01125 | Air Control Ring |
| 6 | 04081 | Rotor Nut |
| 7 | 01007 | Bearing |
| 8 | 01121 | Shim Pack (3/pkg.) |
| 9 | 01008 | Bearing Plate |
| 10 | 50767 | Pin (2) |
| 11 | 01010 | Rotor Spacer |
| 12 | 01120 | Rotor |
| 13 | 01011 | Blade Set (4/pkg.) |
| 14 | 01013 | Cylinder |
| 15 | 01244 | Bearing Plate |
| 16 | 01015 | Bearing |
| 17 | 57342 | Throttle Lever |
| | 01089 | Safety Throttle Lever |
| 18 | 01017 | Pin |
| 19 | 95558 | Retaining Ring |
| 20 | 01243 | Housing |
| 21 | 01477 | Valve Stem |
| 22 | 95730 | O-Ring |
| 23 | 01024 | O-Ring |
| 24 | 01247 | Speed Regulator Assy. |
| 25 | 01464 | Seal |
| 26 | 01472 | Tip Valve |
| 27 | 01468 | Conical Spring |
| 28 | 53190 | Block Plate |
| 29 | 96065 | O-Ring |
| 30 | 01494 | Inlet Adapter |

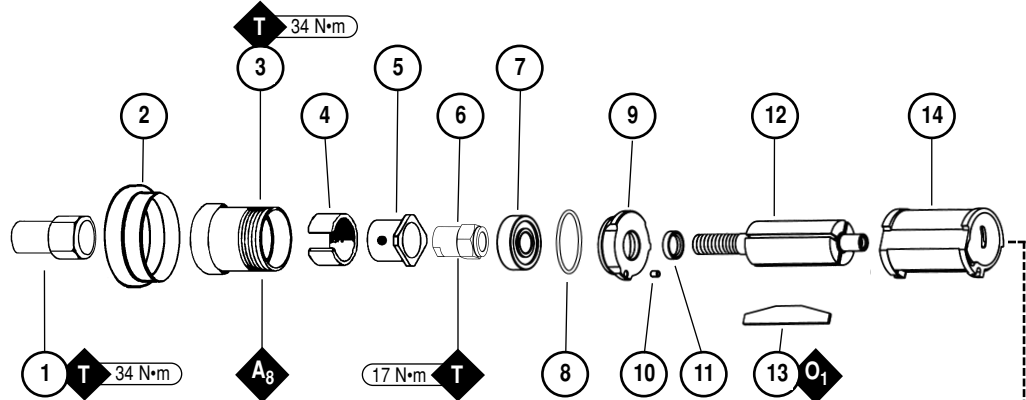

| KEY | |
|-----|---|
| | Oil: O ₁ = Air Lube |
| | Adhesive: A ₈ = Loctite #567 |
| | Torque: N•m x 8.85 = In. - lbs. |

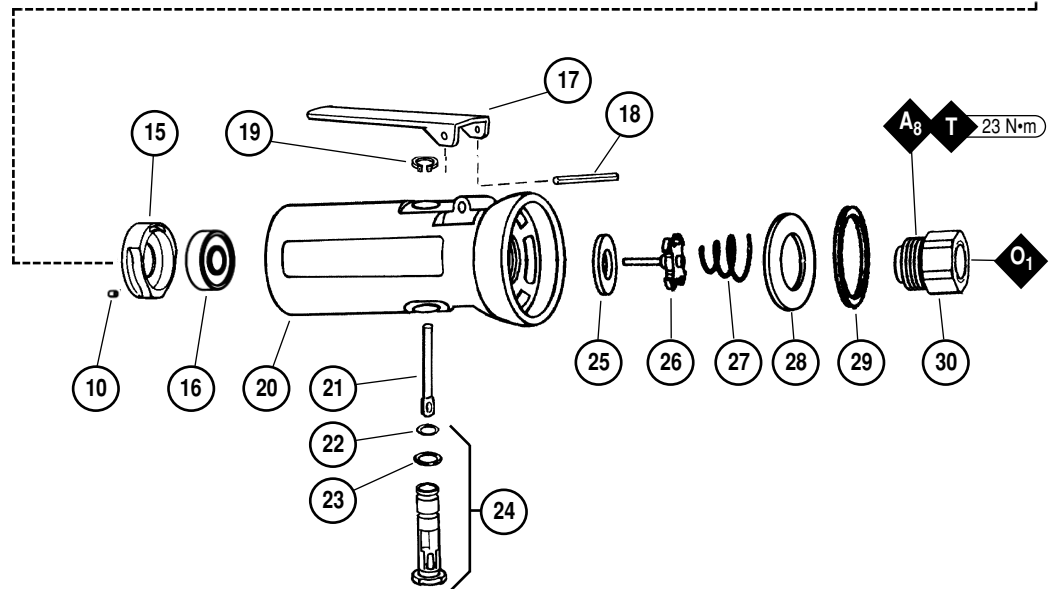

See inside for Important Operating, Maintenance and Safety Instructions.

Important Operating, Maintenance and Safety Instructions

Carefully read all instructions before operating or servicing any Dynabrade® Abrasive Power Tool.

Warning: Hand, wrist and arm injury may result from repetitive work motion and overexposure to vibration.

Important: All Dynabrade Rotary Vane air tools must be used with a Filter-Regulator-Lubricator to maintain all warranties.

Operating Instructions:

Warning: Eye, face, respiratory, sound and body protection must be worn while operating power tools. Failure to do so may result in serious injury or death. Follow safety procedures posted in workplace.

1. With power source disconnected from tool, securely fasten abrasive/accessory on tool.
2. Install air fitting into inlet bushing of tool. **Important:** Secure inlet bushing of tool with a wrench before attempting to install the air fitting to avoid damaging valve body housing.
3. Connect power source to tool. Be careful not to depress throttle lever in the process.
4. Check tool speed with tachometer. If tool is operating at a higher speed than the RPM marked on the tool or operating improperly, the tool should be serviced to correct the cause before use.
5. Air tools are not intended for use in explosive atmospheres and are not insulated for contact with electrical power sources. Sanding/Grinding certain materials can cause explosive dust. It is the employers responsibility to notify the user of acceptable dust levels. Sanding/Grinding can cause sparks which can cause fires or explosions. It is the users responsibility to make sure the work area is free of flammable materials.

Maintenance Instructions:

1. Check tool speed regularly with a tachometer. If tool is operating at a higher speed than the RPM marked on the tool, the tool should be serviced to correct the cause before use.
2. Some silencers on air tools may clog with use. Clean and replace as required.
3. All Dynabrade Rotary Vane air motors should be lubricated. Dynabrade recommends one drop of air lube per minute for each 10 SCFM (example: if the tool specifications state 40 SCFM, set the drip rate of your filter-lubricator at 4 drops per minute). Dynabrade Air Lube (P/N 95842: 1 pt. 473 ml.) is recommended.
4. An Air Line Filter-Regulator-Lubricator must be used with this air tool to maintain all warranties. Dynabrade recommends the following: 11405 Air Line Filter-Regulator-Lubricator — Provides accurate air pressure regulation, two-stage filtration of water contaminants and micro-mist lubrication of pneumatic components. Operates 40 SCFM @ 100 PSIG has 3/8" NPT female ports.
5. Use only genuine Dynabrade replacement parts. To reorder replacement parts, specify the **Model #**, **Serial #**, and **RPM** of your machine.
6. A Motor Tune-Up Kit (P/N 95600) is available which includes assorted parts to help maintain motor in peak operating condition.
7. Mineral spirits are recommended when cleaning the tool and parts. Do not clean tool or parts with any solvents or oils containing acids, esters ketones, chlorinated hydrocarbons or nitro carbons.
8. DO NOT clean or maintain air tools with chemicals that have a low flash point (example: WD-40®).

Safety Instructions:

Products offered by Dynabrade should not be converted or otherwise altered from original design without expressed written consent from Dynabrade, Inc.



- **Important:** User of tool is responsible for following accepted safety codes such as those published by the American National Standards Institute (ANSI).
- Operate machine for one minute before application to workpiece to determine if machine is working properly and safely before work begins.
- Always disconnect power supply before changing abrasive/accessory or making machine adjustments.
- Inspect abrasives/accessories for damage or defects prior to installation on tools.
- Please refer to Dynabrade's Warning/Safety Operating Instructions Tag (Reorder No. 95903) for more complete safety information.
- **Warning:** Hand, wrist and arm injury may result from repetitive work, motion and overexposure to vibration.

Notice

All Dynabrade motors use the highest quality parts and metals available and are machined to exacting tolerances. The failure of quality pneumatic motors can most often be traced to an unclean air supply or the lack of lubrication. Air pressure easily forces dirt or water contained in the air supply into motor bearings causing early failure. It often scores the cylinder walls and the rotor blades resulting in limited efficiency and power. Our warranty obligation is contingent upon proper use of our tools and cannot apply to equipment which has been subjected to misuse such as unclean air, wet air or a lack of lubrication during the use of this tool.

One Year Warranty

Following the reasonable assumption that any inherent defect which might prevail in a product will become apparent to the user within one year from the date of purchase, all equipment of our manufacture is warranted against defects in workmanship and materials under normal use and service. We shall repair or replace at our factory, any equipment or part thereof which shall, within one year after delivery to the original purchaser, indicate upon our examination to have been defective. Our obligation is contingent upon proper use of Dynabrade tools in accordance with factory recommendations, instructions and safety practices. It shall not apply to equipment which has been subject to misuse, negligence, accident or tampering in any way so as to affect its normal performance. Normally wearable parts such as bearings, sanding pads, rotor blades, etc., are not covered under this warranty.

| Model Number | Motor HP (W) | Motor RPM | Sound Level | Air Flow Rate CFM/SCFM (LPM) | Air Inlet Thread | Air Pressure PSIG (Bars) | Weight Pound (kg) | Length Inch (mm) | Height Inch (mm) |
|--------------|--------------|-----------|-------------|------------------------------|------------------|--------------------------|-------------------|------------------|------------------|
| 51130 | .5 (373) | 18,000 | 81 dB(A) | 3/24 (680) | 1/4" NPT | 90 (6.2) | 1.8 (0.8) | 7 (178) | 1-3/4 (44) |

Additional Specifications: Hose I.D. Size 3/8" (10 mm)

Disassembly/Assembly Instructions - Dynastraight® Flapper

**Important: Manufacturer's warranty is void if tool is disassembled before warranty expires.
Please refer to parts breakdown for part identification.**

Motor Disassembly:

1. Disconnect the tool from the air supply.
2. Hold the **01243** Housing in a vise with aluminum or bronze jaws. Secure it at the flats near the inlet area of the housing.
3. Use the **96347** Adjustable Pin Spanner Wrench to remove the **04102** Lock Ring by turning it counterclockwise. Remove the **04078** Felt Silencer and the air control ring.
4. The motor assembly can now be pulled out of the motor housing.
5. Fasten the **96346** 2" Bearing Separator around the portion of the **01013** Cylinder closest to the rear bearing/plate assembly. Place the separator and the motor on the table of the **96232** Arbor Press so that the **51029** Flap Wheel Adapter is pointing toward the floor.
6. Use a 3/16" dia. flat end drive punch and press the rear shaft of the rotor out of the **01015** Bearing.
7. The **01015** Bearing can be removed from the **01244** Rear Bearing Plate with the **96211** Bearing Removal Tool and the arbor press.
8. Hold the vane portion of the **01120** Rotor in a vise with aluminum or bronze jaws and remove the **51029** Flap Wheel Adapter and then the **04081** Rotor Nut by turning them counterclockwise.
9. The **01007** Bearing, **01008** Front Bearing Plate, **01121** Shims, and **01010** Spacer can now be removed from the **01120** Rotor.

Motor Disassembly Complete.

Valve Disassembly:

1. Hold the **01243** Housing in a vise with aluminum or bronze jaws. Secure the flats of the housing near the inlet area with the air inlet pointing up.
2. Hold the **01494** Inlet Adapter stationary with a wrench and remove the air fitting with another wrench. **Important:** The **01494** Inlet Adapter must be held stationary to prevent damage to the **04102** Housing.
3. Remove the **01494** Inlet Adapter to access the **01468** Spring, **01472** Tip Valve, and **01464** Seal.
4. Use a 2.5 mm drive punch to remove the **01017** Pin and the throttle lever.
5. The **01477** Valve Stem can be pulled out of the **01247** Speed Regulator Assembly.
6. Use retaining ring pliers to remove the **95558** Retaining Ring and then push the **01247** Speed Regulator Assembly out of the **01243** Housing.

Valve Disassembly Complete.

Valve Assembly:

Important: Clean and inspect all parts before assembling.

1. Hold the **01243** Housing in a vise with aluminum or bronze jaws. Secure the flats of the housing near the inlet area with the air inlet pointing up.
2. Install the **01247** Speed Regulator Assembly (includes o-rings) into the **01243** Housing and secure it in place with the **95558** Retaining Ring.
3. Insert the **01477** Valve Stem so that the end with the hole fits into the **01247** Speed Regulator Assembly.
4. Install the **01464** Seal into the air inlet so that it is lying flat.
5. Use needle nose pliers to grasp the white portion of the **01472** Tip Valve and insert the metal pin of the tip valve into the hole in the **01477** Valve Stem.
6. Install the **01468** Spring so that the smaller end of the spring fits against the center of the tip valve.
7. Install the **96065** O-Ring onto the **53190** Block Plate and install the block plate along with the o-ring so that the flat side of the block plate is positioned against the **01243** Housing.
8. Apply a small amount of the Loctite #567 (or equivalent) to the threads of the **01494** Inlet Adapter and install the adapter into the housing. (Torque to 23 N•m/200 in.- lbs.)
9. Install the throttle lever and secure it with the **12132** Pin.

Valve assembly Complete.

Motor Assembly:

1. Insert the **01010** Spacer onto the rotor.
2. Select .003" thickness in shims from the **01121** Shim Pack and place these into the **01008** Bearing Plate.
3. Install the **01007** Bearing into the front bearing plate.
4. Slip the front bearing/plate assembly onto the rotor.
5. Install the **04081** Rotor Nut and check the rotor/plate clearance with a .001" (0.03 mm) feeler gauge. The clearance should be .001"-.0015" (0.03-0.04 mm). If the rotor/plate clearance needs adjustment, repeat steps 4-5 and shim as required.
6. Install the **51029** Flap Wheel Adapter.
7. Apply the **95842** Dynabrade Air Lube (10W/NR or equivalent) to the **01011** Blades (4) and install these into the slots of the rotor.
8. Install the **01013** Cylinder over the rotor so that the air inlet opening of the cylinder will align with the air inlet opening of the **01244** Bearing Plate.
9. Use the **96241** Bearing Press Tool (position the raised outside diameter against the outside diameter of the bearing) and **96232** Arbor Press to install the **01015** Bearing.
10. Use the **96241** Bearing Press Tool (position the raised inside diameter against the inside diameter of the bearing) and the **96232** Arbor press to install these parts onto the rear bearing journal of the rotor. **Important:** Press the rear bearing/plate assembly down onto the rotor until the **01244** Bearing Plate comes in contact with the **01013** Cylinder. This fit will establish a preload on the motor bearings producing a "snug fit" between the bearings and the cylinder. If the fit is too tight it will cause the bearings to wear prematurely, too loose and the desired preload will not be achieved. If an adjustment is required disassemble and repeat steps 7-8.
11. Orient the motor assembly so that the air inlet passage in the housing aligns with the air passage in the rear bearing plate and install the motor assembly.

(continued on next page)

Disassembly/Assembly Instructions - Dynastraight® Flapper (continued)

- Wrap the 04078 Felt Silencer around the air control ring and install these into the 04102 Lock Ring.
- Install the 53175 Insulator Collar onto the 04102 Lock Ring.
- Apply a small amount of the #567 Loctite (or equivalent) and install the 04102 Lock Ring onto the 01243 Housing. (Torque to 34 N•m/300 in.- lbs.)

Motor Assembly Complete. Tool Assembly Complete. Please allow 30 minutes for adhesives to cure before operating tool.

Important: Motor should now be tested for proper operation at 90 PSIG. If motor does not operate properly or operates at a higher RPM than marked on the tool, the tool should be serviced to correct the cause before use. Before operating, place 2-3 drops of Dynabrade Air Lube (P/N 95842) directly into air inlet with throttle lever depressed. Operate tool for 30 seconds to determine if tool is operating properly and to allow lubricating oils to properly penetrate motor

Loctite® is a registered trademark of Loctite Corp.

Optional Accessories



95600 Motor Tune-Up Kit:

- Includes assorted parts to help maintain and repair motor.



Dynabrade Air Lube

- Formulated for pneumatic equipment.
- Absorbs up to 10% of its weight in water.
- Prevents rust and formation of sludge.
- Keeps pneumatic tools operating longer with greater power and less down time.

95842: 1 pt. (473 ml)

95843: 1 gal. (3.8 L)



Dynamswivel®

Swivels 360° at two locations which allows an air hose to drop straight to the floor, no matter how the tool is held.

- 94300 1/4" NPT



Collet Inserts

- 50065 – 1/8"
- 50016 – 6 mm
- 50039 – 8 mm



Collet

- 50010 – 1/4"

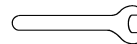

95263 – 17 mm Open-End Wrench



96232 #2 Arbor Press

- This arbor press is ideal for the disassembly and assembly of air motors.



96346 Bearing Separator

- Use the separator to remove gears and bearings.



96347 Pin Spanner Wrench

- An adjustable 3 mm pin wrench that can be used to remove motor lock rings and accessories



96211 Bearing Removal Tool

- This tool is designed to pass through the I.D. of the bearing plate and push against the I.D. of the bearing.



53032 - 1/4" Drill Chuck

- Includes 53052 Mated Chuck Key.



96241 Bearing Press Tool

- This tool is designed to safely press a bearing into a bearing plate and onto a shaft.

Abrasives



Coated Abrasive Flap Wheels

Aluminum Oxide – 2-1/2" Diameter x 1" Wide. Includes 1/4"-20 Male Mandrel.

- 90830 60 Grit
- 90831 80 Grit



Visit Our Web Site: www.dynabrade.com

Email: Customer.Service@Dynabrade.com

DYNABRADE, INC., 8989 Sheridan Drive • Clarence, NY 14031-1490 • Phone: (716) 631-0100 • Fax: 716-631-2073 • International Fax: 716-631-2524
DYNABRADE EUROPE S.à.r.l., Zone Artisanale • L-5485 Wormeldange—Haut, Luxembourg • Telephone: 352 76 84 94 1 • Fax: 352 76 84 95 1

©DYNABRADE, INC., 2002

PRINTED IN USA