

Models:

- 15300 – Basic Tool
- 15302 – Versatility Kit

Dynafite® III

Air Motor and Machine Parts

! WARNING

Always operate, inspect and maintain this tool in accordance with the Safety Code for portable air tools (ANSI B186.1) and any other applicable safety codes and regulations. Please refer to Dynabrade's Warning/Safety Operating Instructions for more complete safety information.

15300 Tool Assembly

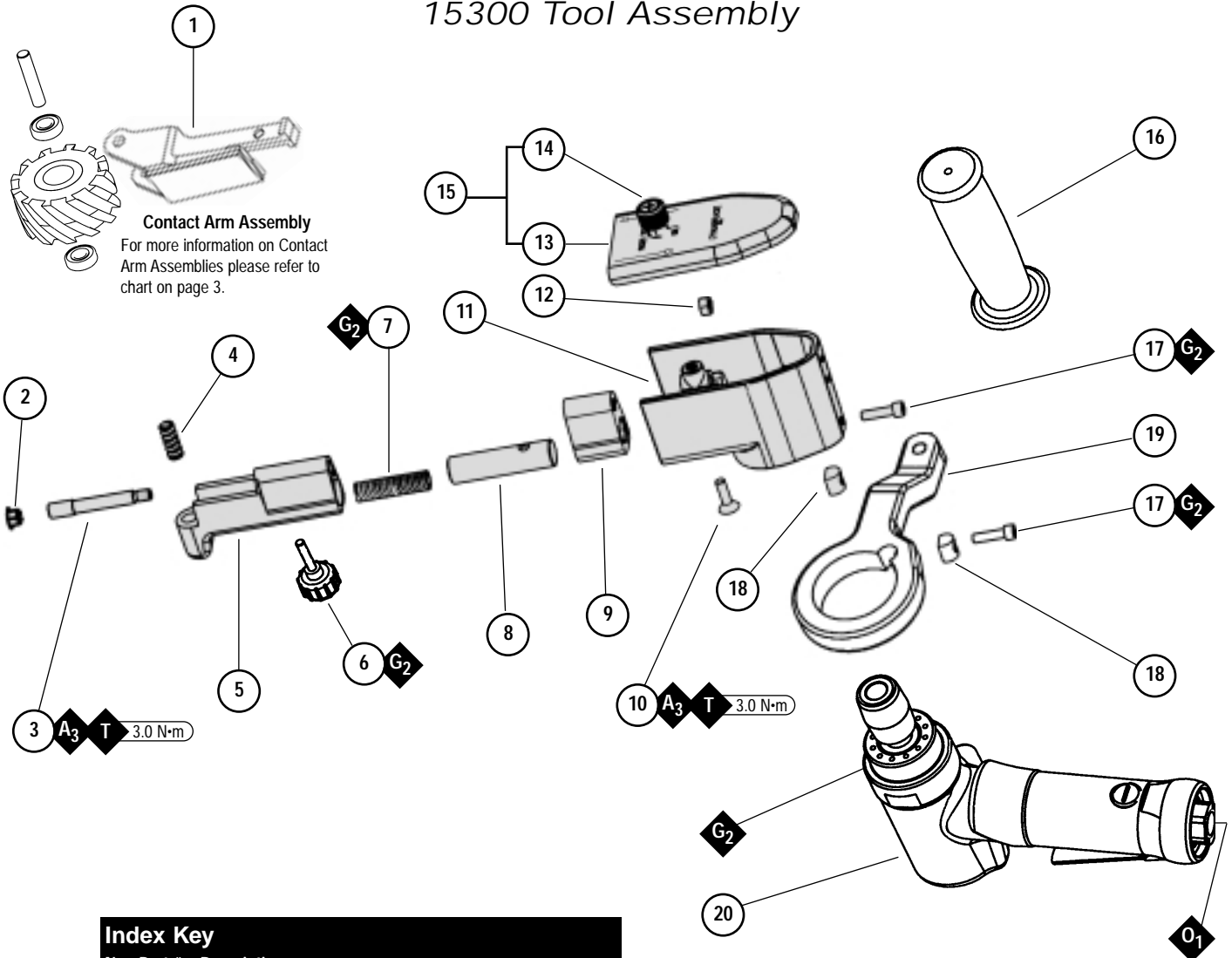

Index Key		
No.	Part #	Description
1	15350	Contact Arm Assy.
2	96334	Plug
3	15308	Guide Post
4	11040	Spring
5	15306	Tension Arm
6	95218	Knob Assy.
7	95426	Spring
8	15307	Tension Shaft
9	15309	Dust Cover
10	95217	Screw
11	15305	Housing
12	96335	Hex Nut
13	15310	Guard
14	15329	Screw
15	15312	Guard Assy.
16	53163	Handle Assy.
17	95311	Screw (2)
18	40029	Motor Lock (2)
19	15338	Handle Support
20	15331	Motor Assy.

KEY	
O	Oil: O ₁ = Air Lube
A	Adhesive: A ₃ = Loctite #242
G	Grease: G ₂ = Loctite #771
T	Torque: N•m x 8.85 = In. - lbs.

Note: Shaded parts represent 15313 Head Assembly.

15331 Air Motor

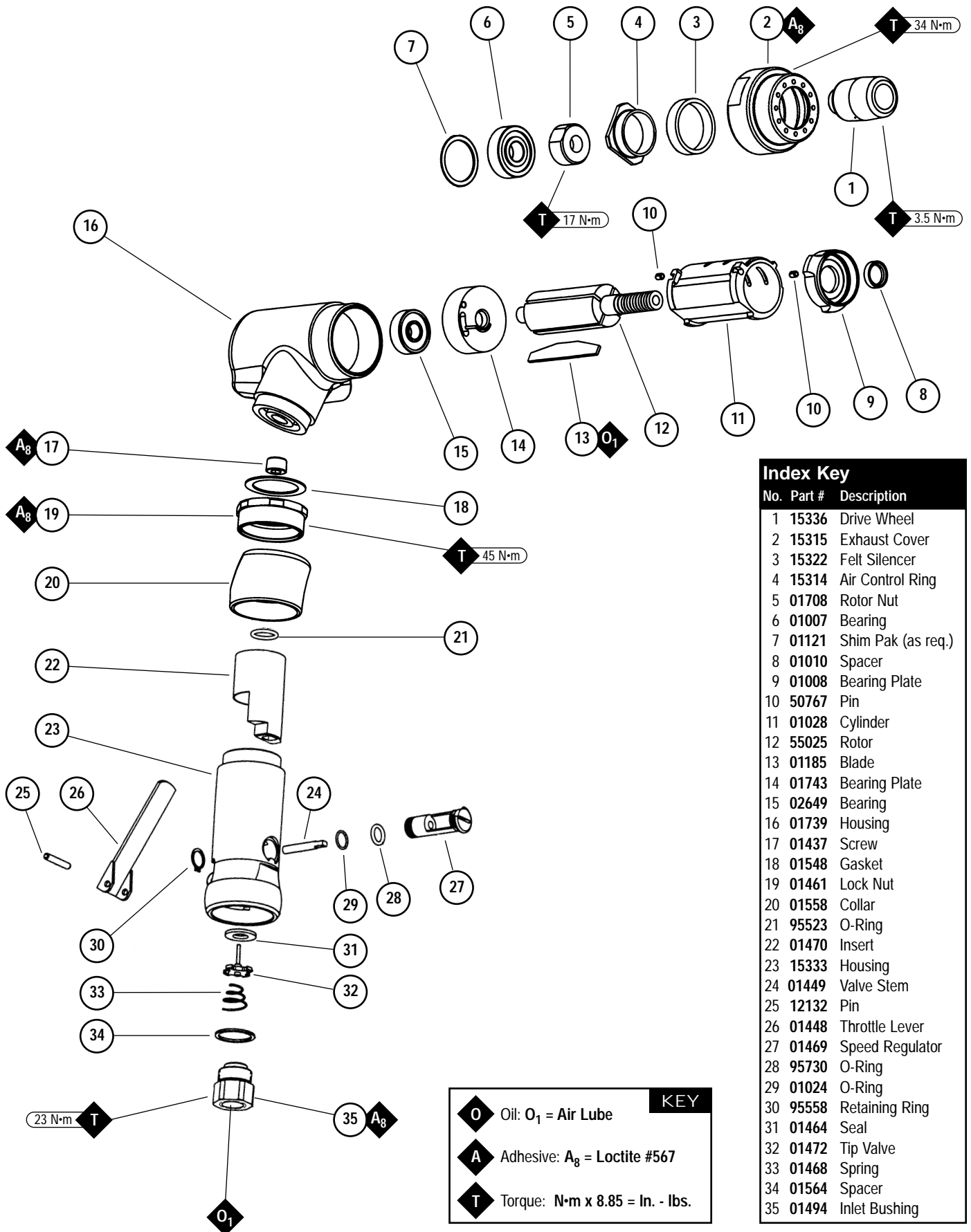

Index Key		
No.	Part #	Description
1	15336	Drive Wheel
2	15315	Exhaust Cover
3	15322	Felt Silencer
4	15314	Air Control Ring
5	01708	Rotor Nut
6	01007	Bearing
7	01121	Shim Pak (as req.)
8	01010	Spacer
9	01008	Bearing Plate
10	50767	Pin
11	01028	Cylinder
12	55025	Rotor
13	01185	Blade
14	01743	Bearing Plate
15	02649	Bearing
16	01739	Housing
17	01437	Screw
18	01548	Gasket
19	01461	Lock Nut
20	01558	Collar
21	95523	O-Ring
22	01470	Insert
23	15333	Housing
24	01449	Valve Stem
25	12132	Pin
26	01448	Throttle Lever
27	01469	Speed Regulator
28	95730	O-Ring
29	01024	O-Ring
30	95558	Retaining Ring
31	01464	Seal
32	01472	Tip Valve
33	01468	Spring
34	01564	Spacer
35	01494	Inlet Bushing

KEY	
O	Oil: O ₁ = Air Lube
A	Adhesive: A ₈ = Loctite #567
T	Torque: N·m x 8.85 = In. - lbs.

Dynaflex® III Contact Arm Assemblies

Contact Wheel Assembly—Includes wheel, bearing and shaft.

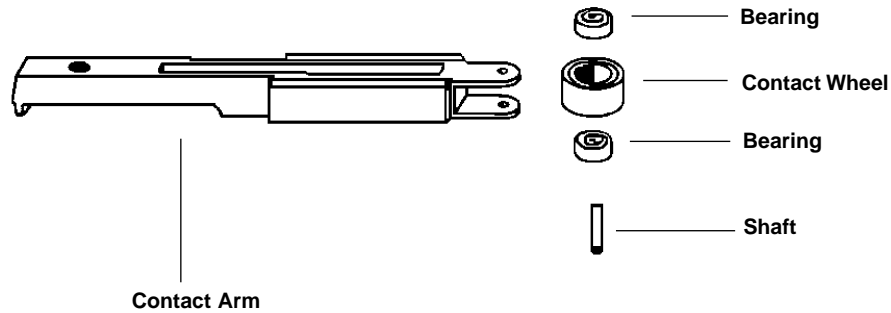

Dynaflex® III Standard and Optional Contact Arms

Part Number	Abrasive Belt Size	Contact Wheel Description	Comments	Contact Wheel Assembly	Contact Wheel Only	Bearing (2) Req.	Shaft
15321	1" x 18"	3/4" Dia. x 7/8" W Rubber	1" W Platen	15320	15318	11052	15328
15326	1" x 24"	3/4" Dia. x 7/8" W Rubber	1" W Platen	15320	15318	11052	15328
15350	1" x 18"	2" Dia. x 1" W Urethane	90 Durometer	15349	11617	11016	15345
15351	1" x 18"	2" Dia. x 1" W Urethane	70 Durometer	15348	11649	11016	15345
15356	1" x 18"	2" Dia. x 5/8" W Urethane	40 Durometer	15346	15342	11016	15345
15357	1" x 18"	2" x 1" W Urethane	V Wheel, 70 Durometer	15347	15343	11016	15345

Optional Dynaflex® II Contact Arms Compatible with the Dynaflex® III

Part Number	Abrasive Belt Size	Contact Wheel Description	Comments	Contact Wheel Assembly	Contact Wheel Only	Bearing (2) Req.	Shaft
11200	1/2" x 18"	5/16" Dia. x 3/8" W Rubber	1/2" W Platen, "Stroke-Sander" Arm	11088 (2)	11077 (2)	11052 (4)	11055 (2)
11203	1/2" x 18"	5/8" Dia. x 3/8" W Rubber	1/2" W Platen	11078	11077	11052	11054
11204	1/8" or 5/16" x 18"	1" Dia. x 3/8" W Radiused Rubber	Loose Belt Application	11080	11079	11052	11054
11206	5/8" or 3/4" x 18"	3/4" Dia. x 5/8" W Rubber	3/4" W Platen	11282	11281	11052	11285
11286	1/2" x 24"	5/8" Dia. x 3/8" W Rubber	1/2" W Platen	11078	11077	11052	11054
11304	1/2" x 18"	5/8" Dia. x 3/8" W Rubber	"Stroke-Sander" Arm-1/2" W Platen	11078	11077	11052	11054
11320	1/2" x 18"	5/8" Dia. 3/8" W Rubber	"Offset Arm" - prevent gouging.	11078	11077	11052	11054
11322	1/2" x 18"	5/8 Dia. x 3/8" W Rubber	Contains two 11395 Guide Wheels - Prevents Undercutting	11090	11077	11052	95610
11337	1/2" x 18"	7/16" Dia. x 3/8" W Steel	1/2" W Platen	11076	11075	11052	11054

See page 6 for Dynaflex® III Abrasives and Accessories.

Assembly/Disassembly for Dynafite® III

Important: Manufacturer's warranty is void if tool is disassembled before warranty expires.

Notice: Dynabrade strongly recommends the use of their **52296** Repair Collar (sold separately) during assembly/disassembly activities. Failure to use this collar will highly increase the risk of damage to the valve body of this tool. Please refer to parts breakdown for part identification.

To Disassemble:

1. Remove Belt Guard, abrasive belt and contact arm assembly. Loosen **95311** Screw (2) and remove housing assembly and **15338** Handle from air motor.

Motor Disassembly:

Important: Do not over tighten vise or housing could be damaged.

1. Secure tool in a padded vise using **52296** Repair Collar or Padded Jaws.
2. Twist the drive wheel counterclockwise and remove. Using a wrench remove **15315** Exhaust Cover (twist counterclockwise). Remove silencers.
3. Pull motor assembly from housing. Fasten a bearing separator around the **01028** Cylinder end, nearest the **01743** Rear Bearing Plate.
4. Place the bearing separator on the table of the arbor press, so that the spindle end of the motor is pointing towards the floor.
5. Using a 3/16" diameter drive punch as a press tool, press the rear portion of the **55025** Rotor out of the **02649** Rear Bearing.
6. Remove **01008** Front Bearing Plate, cylinder, blades(4), and **01010** Spacer from rotor. **Note:** **01008** Front Bearing Plate, **01007** Front Bearing and **01010** Spacer are a slip fit onto rotor. Press **02649** Rear Bearing from **01743** Rear Bearing Plate.
7. With the motor now disassembled, secure the rotor body in a soft jaw vise. Remove the **01078** Rotor Nut.

Motor Disassembly Complete.

Valve Stem/Body Assembly:

1. Secure motor housing in padded vise using **52296** Repair Collar with air inlet bushing facing upwards.
2. Unscrew **01494** Inlet Bushing from valve body and remove **01564** Air Control Ring.
3. Using needle nose pliers, remove **01468** Spring and **01472** Tip Valve. Pick out **01464** Seal.
4. Using a 2.5 mm dia. drift pin, tap out **12132** Pin and remove throttle lever.
5. Remove **95558** Retaining Ring using retaining ring pliers.
6. Push **01469** Speed Regulator from housing.
7. Remove **01470** Insert assembly and **95523** O-ring.

Housing Assembly:

1. Unscrew **15329** Screw and remove **15312** Belt Guard assembly, abrasive belt and contact arm assembly.
2. Loosen **95311** Screw and remove air motor.
3. Remove **96334** Plug.
4. Remove **15308** Guide post and **96335** Hex nut, this will release **15306** Tension arm and **95426** Spring. (Heating of **96335** Nut may be required). **Warning:** **15306** Tension Arm is spring loaded, use caution when removing **15308** Guide Post.
5. Remove **15309** Dust Cover, **95217** Screw and **15307** Tension Shaft. (Heating of **95217** Screw may be required).

Motor Assembly:

Important: Make sure parts are clean and in good condition before assembling.

1. Place **55025** Rotor in padded vise with threaded spindle facing upwards. Slip **01010** Spacer onto rotor.
2. Place a .002" shim into **01008** Front Bearing Plate as an initial spacing and slip **01007** Bearing into plate (**Note:** Shim Pack contains .001" and .002" shims.)
3. Install bearing/bearing plate assembly onto rotor. Tighten **01078** Rotor Nut onto Rotor (torque to 17 N•m/150 in. - lbs.).
4. Check clearance between rotor and bearing plate by using a .001" feeler gauge. Clearance should be at .001" to .0015". Adjust clearance by repeating steps 1-4 with different shim if necessary.
5. Once proper rotor/gap clearance is achieved, install well lubricated **01185** Blades (4) into rotor slots. Dynabrade recommends their air lube P/N **95842**.
6. Install cylinder over rotor. Be sure air inlet holes of cylinder face away from bearing plate and that the **50767** Pin in the front bearing plate aligns correctly with the pin-hole in the cylinder.
7. Press **02694** Rear Bearing into **01743** Rear Bearing Plate. Press bearing/bearing plate assembly onto rotor. Be sure that pin and air inlet holes line-up with pin slot and air inlet holes in cylinder.
Important: Fit must be snug between bearing plates and cylinder. A loose fit will not achieve the proper preload of motor bearings. If too tight, rotor will not turn freely and must then be lightly tapped at press fit end so it will turn freely while still maintaining a snug fit.
8. Secure housing in vise using **52296** Repair Cover or padded jaws so motor cavity faces upwards.

Assembly/Disassembly for Dynafite® III (continued)

9. Install motor assembly into housing (be sure motor drops all the way in). Tighten exhaust cover onto motor housing (torque 34 N•m/300 in. - lbs.).
10. Motor adjustment must now be checked. With motor housing still mounted in vise, pull end of rotor and twist (10-15 lbs. force), rotor should turn freely without drag. If drag or rub is felt, then increase preload or remove shim. Also, push end of rotor and twist (10-15 lbs. force), rotor should turn freely without drag. If drag or rub is felt, then deload or add shim.
11. Tighten **15336** Drive Wheel onto rotor (torque 3.38 N•m/30 in. - lbs.).

Motor Assembly Complete.

Valve Stem/Body Assembly:

1. Install **95523** O-Ring onto **01470** Insert Assembly.
2. Install **01470** Assembly into valve body housing.
3. Insert **01469** Speed Regulator Assembly into valve body housing. Secure with **95558** Retaining Ring.
4. Secure valve body assembly in padded vise using **52296** Repair Collar with air inlet facing upward and throttle lever accessible.
5. Insert **01464** Seal into housing.
6. Line up the hole in **01449** Valve Stem with the hole in the housing (looking past brass bushing). Using needle nose pliers, insert **01472** Tip Valve so that the metal pin passes through the hole in the **01449** Valve Stem.
7. Install **01468** Spring (small end first) over tip valve.
8. Install **01564** Air Control Ring, onto **01494** Inlet bushing.
9. Apply small amount of #567 Loctite® (or equivalent) to threads of **01494** Inlet Bushing and install into valve body. (Torque 34.0 N•m/300 in. lbs.).
10. Install **01448** Throttle Lever and **12132** Pin. Remove valve body assembly from vise.

Housing Assembly:

1. Place **15307** Tension Shaft into housing.
2. Apply one drop of #242 Loctite® (or equivalent) to **95217** Screw and tighten (torque to 3.0 N•m/28 in. lbs.). (Refer to housing diagram for proper location of **95217** Screw).
3. Install **15310** Dust Cover onto **15307** Tension Shaft.
4. Lubricate (#771 Loctite® or equivalent) inside of **15307** Tension Shaft and inside larger diameter of **15306** Tension Arm.
5. Install **95426** Spring into **15307** Tension Shaft and place **15306** Tension Arm over **95426** Spring.
6. Place **15308** Guide post into **15306** Tension Arm, apply one drop of #242 Loctite® (or equivalent) to screw threads.
7. Compress tension arm and secure in place with **96335** Nut. (Torque to 3.0 N•m/300 in. lbs.)
8. Press **96334** Plug into **15306** Tension Arm.
9. With **40029** Motor Lock in place, install air motor assembly into housing and secure in place with lubricated (#771 Loctite® or equivalent) **95311** Screw.
10. Complete assembly by installing contact arm assembly, abrasive belt and place **15310** Belt Guard assembly over **15305** Housing, tighten **15329** Screw into **15305** Housing.

Housing Angle Adjustment:

1. Disconnect power source.
2. To pivot housing, loosen **95311** Motor Lock Screw on housing with the supplied 3/16" hex wrench (P/N – **95134**).
3. Pivot housing to desired angle and retighten the **95311** Motor Lock Screw.

Tool Assembly Complete. Please allow 30 minutes for adhesives to cure before operating tool.

Note: Motor should operate at between 18,000 and 20,000 RPM at 90 PSIG (6.2 Bar). RPM should be checked with a reed tachometer. Before operating, we recommend that 2-3 drops of Dynabrade Air Lube P/N – 95842 (or equivalent) be placed directly into the air inlet with the throttle lever depressed. Throttle lever is preset at the factory at an 1:00 o'clock position.

Important: The regular maintenance of any air tool will contribute to greater efficiency of tool and will prolong tool life. The failure of quality pneumatic air motors can most often be traced to an unclean air supply or the lack of lubrication. Air pressure easily forces dirt or water contained in the air supply into motor bearings causing early failure. It often scores the cylinder walls and the rotor blades resulting in limited efficiency and power. Frequent drainage of water traps in air lines is recommended. Each tool on each drop should also be equipped with a secondary air processing unit. This consists of an in-line Filter-Regulator-Lubricator. All Dynabrade air tools must be used with a Filter-Regulator-Lubricator to maintain all warranties. Our warranty obligation is contingent upon proper use of our tools and cannot apply to equipment which has been subject to misuse such as unclean air, wet air or a lack of lubrication during the use of the tool.

Loctite® is a registered trademark of the Loctite Corp.

Abrasive Belts

Aluminum Oxide Abrasive Belts

18" Long/Unit = 200 Belts					24" Long/Unit = 200 Belts		
Grit	1/2" W	5/8" W	3/4" W	1" W	Grit	1/2" W	1" W
40	90240	90260	90250	90284	40	90441	90478
60	90241	90261	90251	90285	60	90443	90482
80	90242	90262	90252	90286	80	90445	90483
120	90243	90263	90253	90287	120	90447	90484
180	90244	90264	90254	90288	180	90449	90486
220	90245	90265	90255	90289	220	90451	90487
320	90246	90266	90256	90290	320	90453	90488
500	90247	90267	90257	90291	500	90455	90489

Dynacut Abrasive Belts

18" Long/Unit = 200 Belts				
Grit	1/2" W	5/8" W	3/4" W	1" W
60	90168	90170	90172	90177
80	90169	90171	90173	90178

24" Long/Unit = 200 Belts		
Grit	1/2" W	1" W
60	90579	90485
80	90583	90474

Dynapad® Platen Pads

Soft

For deburring and polishing contoured pieces.

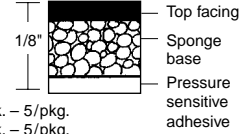

11025 - 1/2" W x 7" L x 1/8" Thk. - 5/pkg.
 11119 - 3/4" W x 7" L x 1/8" Thk. - 5/pkg.
 15323 - 1" W x 2 3/8" L x 1/8" Thk. - 5/Pkg.

Hard

For heavy deburring and polishing.

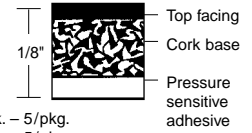

11026 - 1/2" W x 7" L x 1/8" Thk. - 5/pkg.
 11109 - 3/4" W x 7" L x 1/8" Thk. - 5/pkg.
 11132 - 1/2" W x 2 1/2" L x 1/8" Thk. - 5/pkg.
 15324 - 1" W x 2 3/8" L x 1/8" Thk. - 5/Pkg.

Thin

For aggressive grinding.

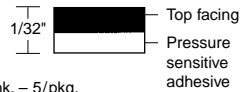

11027 - 1/2" W x 7" L x 1/32" Thk. - 5/pkg.

Accessories



80020 Dynamount Universal Benchmark

- Frees an operators hands for complete control of a work piece.
- Optional **80015** Foot Switch and hose assembly provides on-off foot control of air-tool operation.



96233 Tune-Up Kit

- Includes assorted parts to help maintain and repair motor.



Dynaswivel®

- Swivels 360° at two locations which allows an air hose to drop straight to the floor, no matter how the tool is held.
- 94300 1/4" NPT
- 95461 3/8" NPT
- 95462 1/2" NPT

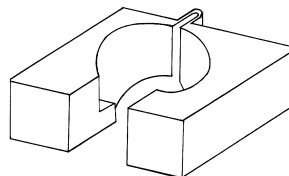

52296 Repair Collar

- Specially designed collar for use in vise.

Important Operating, Maintenance and Safety Instructions

Carefully read all instructions before operating or servicing any Dynabrade® Abrasive Power Tool.

Warning: Hand, wrist and arm injury may result from repetitive work motion and overexposure to vibration.

Important: All Dynabrade air tools must be used with a Filter-Regulator-Lubricator to maintain all warranties.

Operating Instructions:

Warning: Eye, face, respiratory, sound, and body protection must be worn while operating power tools. Failure to do so may result in serious injury or death. Follow safety procedures posted in workplace.

1. With power source disconnected from tool, securely fasten abrasive/accessory on tool.
2. Connect power source to tool. Be careful **not** to depress throttle lever in the process.
3. Check tool speed with tachometer. If tool is operating at a higher speed than the RPM marked on the tool or operating improperly, the tool should be serviced to correct the cause before use.
4. Always work off the return side of the abrasive belt. This will ensure superior tracking and reduce down time of tool.

Abrasive Belt/Contact Arm Change Instructions:

To Change Belt:

1. Disconnect power source.
2. Remove cover.
3. Pull back on tension arm assembly.
4. Remove and replace abrasive belt and cover.
5. Connect power source.
6. Adjust belt tracking by turning **95218** Rough Adjustment Knob to the left or right accordingly while machine is running.

To Change Contact Arm Assembly:

1. Disconnect power source.
2. Remove cover.
3. Pull back on tension arm assembly and remove abrasive belt.
4. Remove **95218** Rough Adjustment Knob.
5. Remove contact arm and replace with desired arm, making sure that the tab on the end of the arm is facing downward.
6. Replace **95218** Knob.
7. Install abrasive belt and cover.
8. Connect power source and adjust belt tracking by turning **95218** Knob to the left or right accordingly while machine is running.

Housing Angle Adjustment:

To pivot housing, loosen **95311** Screw on housing with the supplied 9/64" hex wrench (P/N – **95134**). Pivot housing to desired angle and retighten **95311** Screw.

Maintenance Instructions:

Products offered by Dynabrade should not be converted or otherwise altered from original design without the expressed written consent from Dynabrade, Inc.

1. All Dynabrade air motors should be lubricated. Dynabrade recommends one drop of air lube per minute for each 10 SCFM (example: if the tool specifications state 40 SCFM, set the drip rate of your filter-lubricator at 4 drops per minute). Dynabrade Air Lube (P/N **95842**: 1pt. 473ml.) is recommended.
2. An Air Line Filter-Regulator-Lubricator must be used with this air tool to maintain all warranties. Dynabrade recommends the following: **11289** Air Line Filter-Regulator-Lubricator — Provides accurate air pressure regulation, two-stage filtration of water contaminants and positive-drip lubrication of pneumatic components. Operates 28 SCFM @ 90 PSIG has 3/8" NPT female ports.
3. Frequent drainage of water traps in air lines is recommended.
4. Some silencers on air tools may clog with use. Clean and replace as required.
5. A Motor Tune-Up Kit (P/N **96024**) is available which includes assorted parts to help maintain and repair motor.

Safety Instructions:

Products offered by Dynabrade should not be converted or otherwise altered from original design without expressed written consent from Dynabrade, Inc.



- **Warning:** Eye, face and body protection must be worn while operating power tools. Failure to do so may result in serious injury or death. Follow safety procedures posted in workplace.
- **Important:** User of tool is responsible for following accepted safety codes such as those published by the American National Standards Institute (ANSI).
- Tool RPM must never exceed abrasive/accessory RPM rating, regardless of tool capacity.
- Operate machine for 30 seconds before application to workpiece to determine if machine is working properly and safely before work begins.
- Always use proper guards. Make sure guards are in proper position, secure and in good repair.
- Always disconnect power supply before changing abrasive or making machine adjustments.
- Inspect abrasives and accessories for damage or defects prior to installation on tools.
- Please refer to Dynabrade's Warning/Safety Operating Instructions Tag (Reorder No. **95903**) for more complete safety information.
- **Warning:** Hand, wrist and arm injury may result from repetitive work, motion and overexposure to vibration.



Toll Free (U.S.A.) 1-800-828-7333
Toll Free (Can.) 1-800-344-1488

Visit our Web Site: www.dynabrade.com

Email: Customer.Service@Dynabrade.com

DYNABRADE, INC., 8989 Sheridan Drive • Clarence, NY 14031-1490 • Phone: (716) 631-0100 • Fax: 716-631-2073 • International Fax: 716-631-2524
DYNABRADE EUROPE S.à.r.l., Zone Artisanale • L-5485 Wormeldange—Haut, Luxembourg • Telephone: 352 76 84 94 1 • Fax: 352 76 84 95 1
©DYNABRADE, INC., 2000 PRINTED IN USA