

Dynafile®

Air Tool Manual – Safety, Operation and Maintenance

SAVE THIS DOCUMENT, EDUCATE ALL PERSONNEL

Models:

14000 – 20,000 RPM

14010 – Versatility Kit



! WARNING

Read and understand this tool manual before operating your air tool. Follow all safety rules for the protection of operating personnel as well as adjacent areas. Always operate, inspect and maintain this tool in accordance with the American National Safety Institute (ANSI) Safety Code for Portable Air Tools – B186.1. For additional safety information, refer to Safety Requirements for the Use, Care and Protection of Abrasive Wheels – ANSI B7.1, Code of Federal Regulation – CFR 29 Part 1910, European Committee for Standards (EN) Hand Held Non-Electric Power Tools – Safety Requirements and applicable State and Local Regulations.

SAFETY LEGEND

	! WARNING Read and understand tool manual before work starts to reduce risk of injury to operator, visitors, and tool.	! WARNING Practice safety requirements. Work alert, have proper attire, and do not operate tools under the influence of alcohol or drugs.	
	! WARNING Eye protection must be worn at all times, eye protection to conform to ANSI Z87.1.	! WARNING Ear protection to be worn when exposure to sound, exceeds the limits of applicable Federal, State or local statutes, ordinances and/or regulations.	
	! WARNING Respiratory protection to be used when exposed to contaminants that exceed the applicable threshold limit values required by law.	! WARNING Air line hazard, pressurized supply lines and flexible hoses can cause serious injury. Do not use damaged, frayed or deteriorated air hoses and fittings.	

SAFETY INSTRUCTIONS

Carefully Read all instructions before operating or servicing any Dynabrade® Abrasive Power Tool.

Products offered by Dynabrade are not to be modified, converted or otherwise altered from the original design without expressed written consent from Dynabrade, Inc.

Tool Intent: Dynafile® abrasive belt machine replaces tedious hand filing and sanding and can be used for grinding, deburring, blending and polishing. Can be used on most materials including metal, plastic, fiberglass, composites, rubber, glass and stone.

Do Not Use Tool For Anything Other Than Its Intended Applications.

Training: Proper care, maintenance, and storage of your tool will maximize its performance.

- Employer's Responsibility – Provide Dynafile® operators with safety instructions and training for safe use of tools and accessories.

Accessory Selection:

- Abrasive/accessory RPM (speed) rating MUST be approved for AT LEAST the tool RPM rating.
- Before mounting an accessory, visually inspect for defects. Do not use defective accessories.
- Mount only recommended accessories. See back page of manual and Dynabrade catalog.
- Follow tool specifications before choosing size and type of accessory.
- Only use recommended fittings and air line sizes. (See tool Machine Specifications table.)

OPERATING INSTRUCTIONS

Warning: Always wear eye protection. Operator of tool is responsible for following: accepted eye, face, respiratory, hearing and body protection.

Caution: Hand, wrist and arm injury may result from repetitive work, motion and overexposure to vibration.

(Continued on next Page.)

OPERATING INSTRUCTIONS (continued)

- Keep hand and clothing away from working end of the air tool.

Operation: Be sure that any loose clothing, hair and all jewelry is properly restrained.

- Secure inlet bushing on air tool with a wrench before attempting to install the air fitting to avoid damaging housing assembly.
- Check tool RPM (speed) with tachometer with air pressure set at 90 PSIG while the tool is running. If tool is operating at a higher speed than the RPM marked on the tool housing, or operating improperly, the tool must be serviced and corrected before use.

Caution: Tool RPM must never exceed abrasive/accessory RPM rating. Check accessory manufacturer for details on maximum operating speed or special mounting instructions.

- Disconnect air hose from tool when changing belts and contact arms.
- Connect air tool to power source. Be careful NOT to depress throttle lever in the process. **Do not expose air tool to inlet pressure above 90 PSIG or (6.2 Bars).**

Caution: After installing the accessory, before testing or use and/or after assembling tool, the Dynafile® must be started at a reduced speed to check for good balance. Gradually increase tool speed. DO NOT USE if tool vibration is excessive. Correct cause, and retest to insure safe operation.

- Make sure that work area is uncluttered, and visitors are at a safe range from the tools and debris.
- Use a vise or clamping device to hold work piece firmly in place.
- Do not apply excessive force on tool or apply "rough" treatment to it.
- Always work with a firm footing, posture and proper lighting.

Report to your supervisor any condition of the tool, accessories, or operation you consider unsafe.

Air System

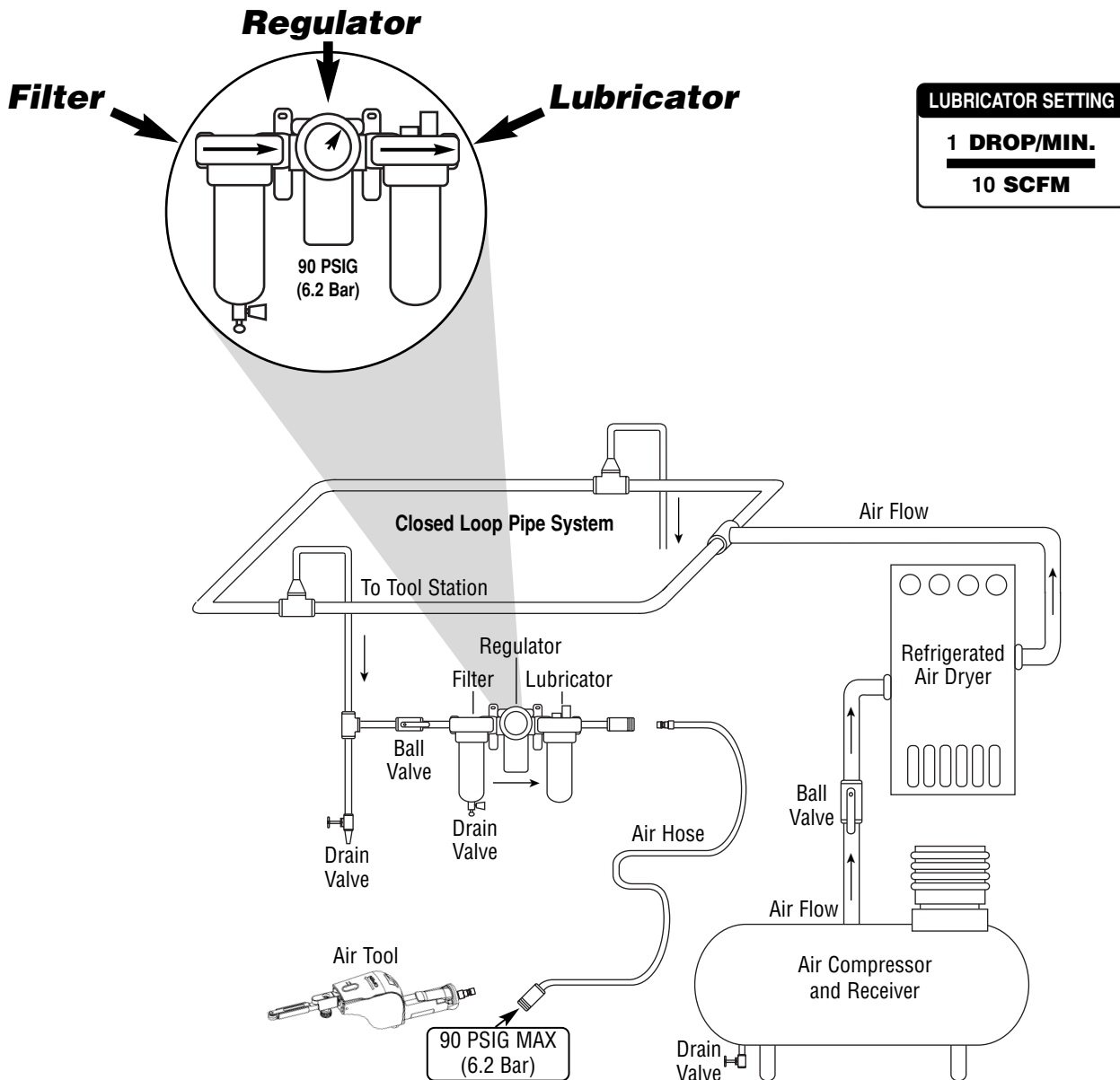

- Ideally the air supply should be free from moisture. Incorporating a refrigerated air dryer after the compressor and drain valves at each tool station (as shown) further reduces moisture from condensation in the air supply.

- Dynabrade Air Power Tools are designed to operate at 90 PSIG (6.2 Bar/620 kPa) maximum air pressure at the tool inlet, when the tool is running. Use recommended regulator to control air pressure.

Maintenance Instructions

Important: A Preventative Maintenance Program is recommended whenever portable power tools are used.

- Use only genuine Dynabrade replacement parts to insure quality. To order replacement parts, specify **Model #**, **Serial #** and **RPM** of your air tool.
- All Dynabrade Rotary Vane air tools must be used with a Filter-Regulator-Lubricator to maintain all warranties. Dynabrade recommends the following: **11405** Air Filter-Regulator-Lubricator (FRL) – Provides accurate air pressure regulation and two stage filtration of water contaminants. Operates 40 SCFM/1,133 LPM @ 100 PSIG with 3/8" NPT female ports.
- Dynabrade recommends one drop of air lube per minute for each 10 SCFM (example: if the tool specification states 40 SCFM, set the drip rate on the filter-lubricator to 4 drops per minute). Dynabrade Air Lube (P/N **95842**: 1 pt 473 ml) is recommended.

Routine Preventative Maintenance: Check free speed of Dynaflex® using a tachometer.

- Mineral spirits are recommended when cleaning the tool and parts. Do not clean tool or parts with any solvents or oils containing acids, esters, ketones, chlorinated hydrocarbons or nitro carbons.
- DO NOT clean or maintain tools with chemicals that have a low flash point (example: WD-40®).
- A Motor Tune-Up Kit (P/N **95600**) is available which includes high wear and medium wear motor parts.
- Air tool labels must be kept legible at all times, if not, reorder label(s) and replace. User is responsible for maintaining specification information i.e.: Model #, S/N, and RPM. (See Assembly Breakdown)
- Blow air supply hose out prior to initial use.
- Visually inspect air hoses and fittings for frays, visible damage and signs of deterioration. Replace damaged or worn components.
- Refer to Dynabrade's Warning/Safety Operating Instructions Tag (Reorder No. **95903**) for safety information.

After maintenance is performed on tool, add a few drops of Dynabrade Air Lube (P/N **95842**) to the air line and start the tool a few times to lubricate air motor. Check for excessive tool vibration.

Handling and Storage:

- Use of tool rests, hangers and/or balancers is recommended.
- Protect tool inlet from debris (see Notice below).
- DO NOT carry tool by air hose.
- Protect abrasive accessories from exposure to water, solvents, high humidity, freezing temperature and extreme temperature changes.
- Store accessories in protective racks or compartments to prevent damage.

Machine Specifications

Model Number	Motor HP (W)	Motor RPM	Sound Level	Abrasive Belt Size Inch (mm)	Maximum Air Flow CFM/SCFM (LPM)	Max. SFPM (SMPM)	Weight Pound (kg)	Length Inch (mm)	Height Inch (mm)
All Models	.5 (373)	20,000	84 dB(A)	1/8-1/2 (3-13) W x 24 (610) L	4/29 (821)	5,800 (1,762)	3.0 (1.4)	15.0 (381)	4.0 (102)

Additional Specifications: Air Inlet Thread 1/4" NPT • Hose I.D. Size 3/8" (10 mm) • Air Pressure 90 PSIG (6.2 Bars)

Notice

All Dynabrade motors use the highest quality parts and metals available and are machined to exacting tolerances. The failure of quality pneumatic motors can most often be traced to an unclean air supply or the lack of lubrication. Air pressure easily forces dirt or water contained in the air supply into motor bearings causing early failure. It often scores the cylinder walls and the rotor blades resulting in limited efficiency and power. Our warranty obligation is contingent upon proper use of our tools and cannot apply to equipment which has been subjected to misuse such as unclean air, wet air or a lack of lubrication during the use of this tool.

One Year Warranty

Following the reasonable assumption that any inherent defect which might prevail in a product will become apparent to the user within one year from the date of purchase, all equipment of our manufacture is warranted against defects in workmanship and materials under normal use and service. We shall repair or replace at our factory, any equipment or part thereof which shall, within one year after delivery to the original purchaser, indicate upon our examination to have been defective. Our obligation is contingent upon proper use of Dynabrade tools in accordance with factory recommendations, instructions and safety practices. It shall not apply to equipment which has been subject to misuse, negligence, accident or tampering in any way so as to affect its normal performance. Normally wearable parts such as bearings, contact wheels, rotor blades, etc., are not covered under this warranty.

Dynafile®

Complete Assembly Breakdown

Index Key

No. Part # Description

- 1 **Contact Arm Assembly**
(See pages 8-11)
- 2 **95218** Knob Assembly
- 3* **11420** Idler Arm
(Incl. **95070** Threaded Insert)
- 4 **11359** Tension Spring
- 5* **95162** Screw (2)
- 6* **11011** Idler Wheel Assembly (2)
(Incl. **95162** Screw, **11013** Bearing and **11006** Idler Wheel.)
- 7 **95216** Pivot Pin
- 8 **11418** Housing
- 9 **95168** Screw
- 10 **40029** Motor Lock
- 11 **11419** Cover
- 12 **11424** Wave Spring
- 13 **01197** Air Motor
- 14 **01111** Drive Wheel
- 15 **10295** Screen
- 16 **04087** Lock Ring
- 17 **04078** Felt Silencer
- 18 **04084** Air Control Ring
- 19 **04081** Rotor Nut
- 20 **01007** Bearing
- 21 **01121** Shim Pack (3/pkg.)
- 22 **01008** Bearing Plate
- 23 **50767** Pin (2)
- 24 **01010** Rotor Spacer
- 25 **01013** Cylinder
- 26 **01011** Blade (4) (4/pkg.)
- 27 **01120** Rotor
- 28 **01244** Bearing Plate
- 29 **01015** Bearing
- 30 **95558** Retaining Ring
- 31 **30420** Housing
- 32 **01477** Valve Stem
- 33 **95730** O-Ring
- 34 **01024** O-Ring
- 35 **01247** Speed Regulator Assembly
- 36 **01090** Throttle Lever
01089 Safety Throttle Lever
- 37 **01017** Pin
- 38 **01464** Seal
- 39 **01472** Tip Valve
- 40 **01438** Spring
- 41 **53190** Block Plate
- 42 **96065** O-Ring
- 43 **01494** Inlet Adapter

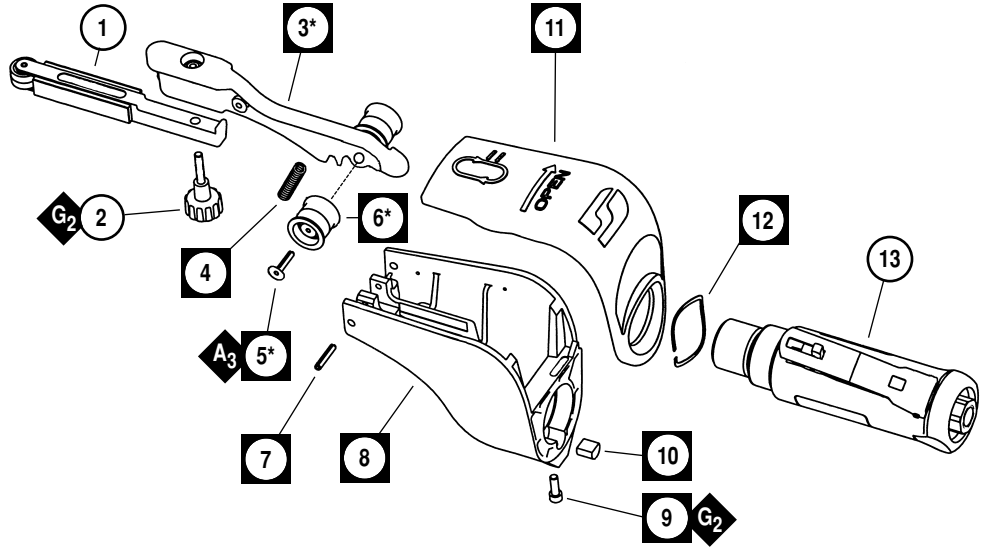

*Indicates individual parts that are included in 11421 Idler Arm Assembly

Note: All Boxed index numbers represent 11431 Housing Assembly.

01197 Air Motor with 01111 Drive Wheel

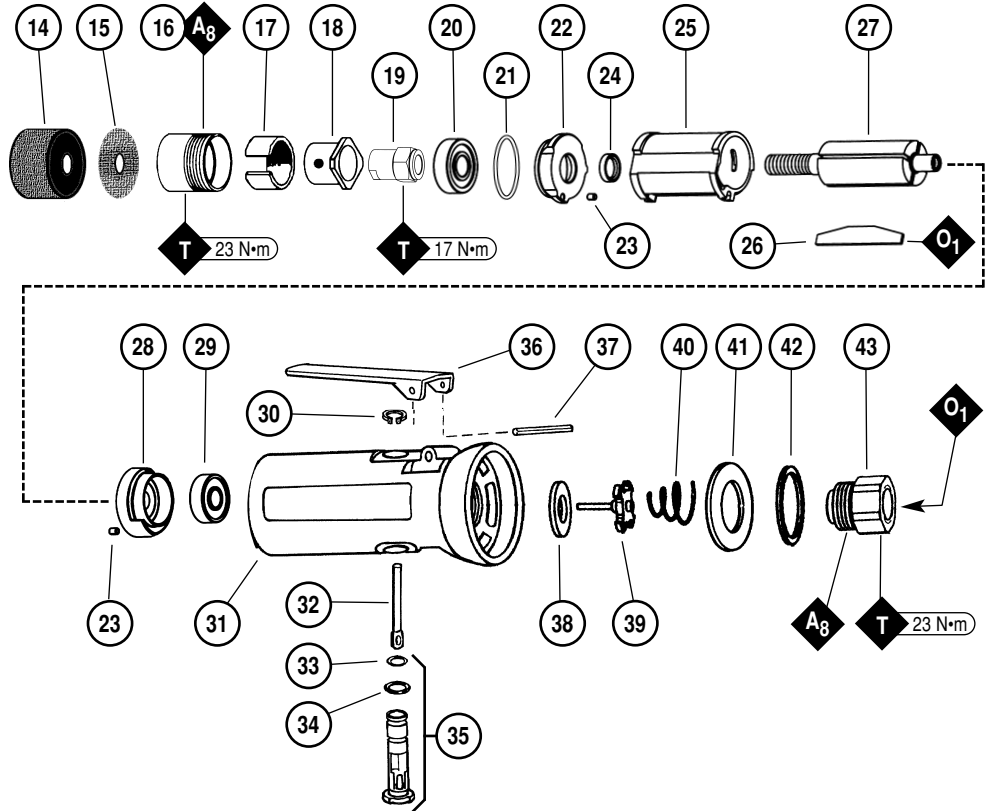

KEY	
O	Oil: O ₁ = Air Lube
A	Adhesive: A ₃ = Loctite #242 A ₈ = Loctite #567
T	Torque: N·m x 8.85 = In. - lbs.
G	Grease: G ₂ = Loctite #771

Note: 50971 Lock Ring Wrench is available for removal/installation of 04087 Lock Ring. See inside for Important Operating, Maintenance and Safety Instructions before operating tool.

Disassembly/Assembly Instructions - Dynafile®

Important: Manufacturer's warranty is void if tool is disassembled before warranty expires.

Notice: A complete Tune-Up Kit, part number 95600, is available which includes assorted parts to help maintain motor in peak condition. Please refer to parts breakdown for part identification.

Disconnect tool from power source before tool repair.

To Disassemble:

1. Disconnect the tool from air supply.
2. Secure the 11418 Housing in a padded vise.
3. Use a 9/64" hex key to loosen 95168 Screw and to remove the 01197 Air Motor, 11424 Wave Spring, and 11419 Cover.
4. To remove the 11421 Idler Arm Assembly use a 1/8" dia. punch and drive out the 95216 Pivot Pin.

Motor Disassembly:

1. Hold the 01197 Air Motor in a soft jaw (aluminum or bronze) vise securing it at the flats near the inlet area of the housing.
2. To remove the 01111 Drive Wheel insert a 3/16" hex key through the center of the drive wheel and into the 01120 Rotor.
3. Hold the drive wheel with pliers or pipe wrench and turn the 01111 Drive Wheel counter-clockwise to remove.
4. Use an adjustable pin wrench or 50971 Lock Ring Wrench to remove the 04087 Lock Ring by turning it counter-clockwise. Remove the 04078 Felt Silencer and air control ring.
5. The motor assembly can be pulled out of the motor housing.
6. Fasten a 2" bearing separator around the portion of the 01013 Cylinder closest to the rear bearing/bearing plate assembly. Place the separator and motor on the table of an arbor press so that the threaded rotor shaft points toward the floor.
7. Use a 3/16" dia. drive punch and press the rear shaft of the rotor out of the 01015 Rear Motor Bearing.
8. Remove the 01015 Bearing with 96211 Bearing Removal Tool and an arbor press.
9. Hold the vane portion of the rotor in a soft jaw (aluminum or bronze) vise and turn the 04081 Rotor Nut counter-clockwise.
10. The 01007 Bearing, 01008 Front Bearing Plate, 01121 Shims, and 01010 Spacer can now be removed from the 01120 Rotor.

Motor Disassembly Complete.

Valve Body Disassembly:

1. Position the flats of the 30420 Housing in a soft jaw (aluminum or bronze) vise with the air inlet pointing up.
2. Hold the 01494 Inlet Adapter stationary with a wrench and remove any air fitting. **Important:** The 01494 Inlet Adapter must be held securely to prevent damage to the 30420 Housing.
3. Remove 01494 Inlet Adapter to access the 01438 Spring, 01472 Tip Valve, and 01464 Seal.
4. Use a 2.5 mm drive punch to remove 01017 Pin and the throttle lever.
5. The 01477 Valve Stem can be pulled out of the 01247 Speed Regulator Assembly.
6. Use retaining ring pliers to remove the 95558 Retaining Ring and then push 01247 Speed Regulator Assembly out of the 30420 Housing.

Disassembly Complete.

Motor Assembly:

Important: Be sure parts are clean and in good repair before assembling.

1. Place 01120 Rotor in an aluminum or bronze jaw vise with a threaded spindle pointing upwards.
2. Slip 01010 Spacer onto rotor.
3. Place a .002" shim into front bearing plate as an initial spacing and slip 01007 Bearing into plate.
Note: 01121 Shim Pack contains .001" and .002" shims.
4. Install bearing/bearing plate assembly onto rotor.
5. Install 04081 Rotor Nut onto assembly.
6. Tighten rotor nut onto rotor (torque to 17 N•m/150 in. - lbs.).
7. Check clearance between rotor and bearing plate by using a .001" feeler gauge. Clearance should be at .001" to .0015". Adjust clearance by repeating steps 1-4 with different shim if necessary.
8. Once proper rotor/gap clearance is achieved, install well lubricated 01011 Blades (4) into rotor slots. Dynabrade air lube P/N 95842 is recommended for lubrication.
9. Install cylinder over rotor. Be sure air inlet holes of cylinder face away from bearing plate.
10. Press 01015 Rear Bearing into 01244 Rear Bearing Plate. Press bearing/bearing plate assembly onto rotor (96241 Bearing Press Tool is available). Be sure that pin and air inlet holes line-up with pin slot and air inlet holes in cylinder.
Important: Fit must be snug between bearing plates and cylinder. If too tight, rotor will not turn freely. Rotor must then be lightly tapped at press fit end so it will turn freely while still maintaining a snug fit. A loose fit will not achieve the proper preload of motor bearings.
11. Secure motor housing in padded vise so motor cavity faces upwards.
12. Install motor assembly into housing, making sure motor drops all the way into housing.
Note: Align the rear bearing plate node with the notch inside the housing.
13. Insert air control ring and 04078 Felt Silencer into 04087 Lock Ring and install onto motor housing (torque 23 N•m/200 in. - lbs.).
14. Motor adjustment must now be checked. With motor housing still mounted in vise, pull end of rotor and twist (10-15 lbs. force), rotor should turn freely without drag. If drag or rub is felt, then increase preload or remove shim. Also, push end of rotor and twist (10-15 lbs. force), rotor should turn freely without drag. If drag or rub is felt, then deload or add shim.
15. Install 10295 Screen and 01111 Drive Wheel.

(continued on next page)

Disassembly/Assembly Instructions - Dynafile® (continued)

- Place **11418** Housing in a padded vise, slip **11424** Wave Spring, then **11419** Cover over the lock ring on the motor and install **01197** Motor to housing.
- Tighten **95168** Screw with 9/64" allen wrench.
- Install **11359** Tension Spring, **11421** Idler Arm Assembly, and **95216** Pivot Pin. **Important:** Use 1/8" diameter drive pin punch to line-up **11421** Idler Arm Assembly with **11418** Housing.
- Install **11419** Cover, contact arm assembly and abrasive belt.

Valve Body Assembly:

- Insert **01247** Speed Regulator Assembly with o-rings into valve body. Secure with **95558** Retaining Ring.
- Secure valve body in padded vise with air inlet point up.
- Insert **01464** Seal into housing.
- Line up hole in valve stem with hole in housing (looking past brass bushing). Insert **01472** Tip Valve so that the metal pin passes through the hole in the valve stem. Install **01438** Spring (small end towards tip valve).
- Install **53190** Block Plate along with **96065** O-Ring into housing.
- Apply Loctite #567 PST Pipe Sealant to threads of **01494** Inlet Adapter and install into valve body (torque 23 N•m/200 in. - lbs.).
- Install throttle lever and **01017** Pin.

Tool Assembly Complete. Please allow 30 minutes for adhesives to cure before operating tool.

Important: Motor should now be tested for proper operation at 90 PSIG. If motor does not operate properly or operates at a higher RPM than marked on the tool, the tool should be serviced to correct the cause before use. Before operating, place 2-3 drops of Dynabrade Air Lube (P/N **95842**) directly into air inlet with throttle lever depressed. Operate tool for 30 seconds to determine if tool is operating properly and to allow lubricating oils to properly penetrate motor

Loctite® is a registered trademark of Loctite Corp.

Abrasive Belt Change and Removal:

To Remove Belt:

- Open **11419** Cover.
- Depress idler arm lever and pull belt away from the contact wheel.
- Slip belt off drive wheel.

To Replace Belt:

- Create a loop with belt by pinching together the sides of belt in the middle.
- Slip one loop under the **01111** Drive Wheel and around the idler arm.
- Depress idler arm lever and pull belt toward the contact wheel.
- Slip belt over contact wheel.
- Connect tool to power source.
- Adjust belt tracking using **95218** Knob.

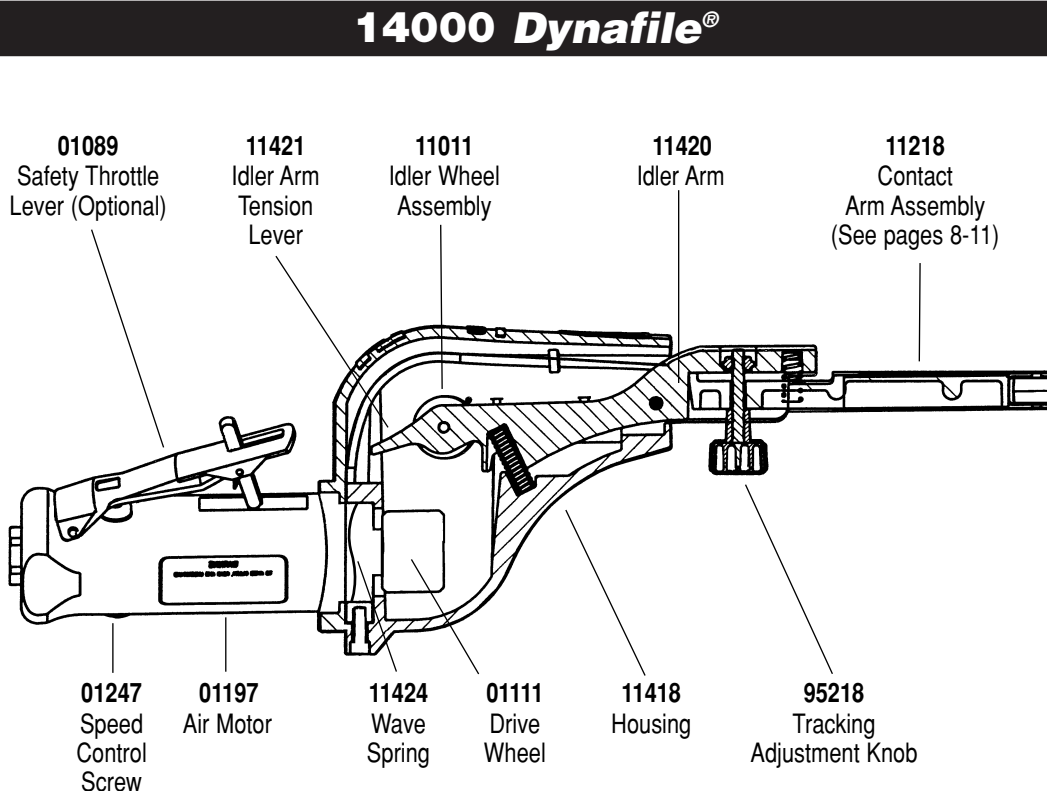

Preventative Maintenance Schedule

For All Dynafire®

This service chart is published as a guide to expectant life of component parts. The replacement levels are based on average tool usage over one year. Dynabrade Inc. considers one year usage to be 1,000 hours or 50% of a man year. Parts included in motor tune-up kit are identified by High Wear and Medium Wear items.

Parts Common to all Models:

LEGEND	
X	Type of wear, no other comments apply.
L	Easily lost. Care during assembly/disassembly.
D	Easily damaged during assembly/disassembly.
R1	Replace each time tool is disassembled.
R2	Replace each second time tool is disassembled.



95600 – Motor Tune-Up Kit

- Tune-Up Kit includes high wear and medium wear motor parts.

Index #	Part Number	Description	Number Required	High Wear 100%	Medium Wear 70%	Low Wear 30%	Non-Wear 10%
1	See Note	Contact Arm Assembly	1				
2	95218	Knob Assembly	1			X	
3	11420	Idler Arm (Incl. 95070 Threaded Insert)	1				X
4	11359	Tension Spring	1			X	
5	95162	Screw	2				X
6	11011	Idler Wheel Assembly (Incl. 95162 Screw, 11013 Bearing & 11006 Idler Wheel)	2			X	
7	95216	Pivot Pin	1			X	
8	11418	Housing	1				X
9	95168	Screw	1			X	
10	40029	Motor Lock	1			L	
11	11419	Cover	1				X
12	11424	Wave Spring	1				X
13	01197	Air Motor	1				X
14	01111	Drive Wheel	1			X	
15	10295	Screen	1		L		
16	04087	Lock Ring	1				X
17	04078	Felt Silencer	2		X		
18	04084	Air Control Ring	1				X
19	04081	Rotor Nut	1				X
20	01007	Bearing	1		X		
21	01121	Shim Pack (3/pkg.)	1	D			
22	01008	Bearing Plate	1			X	
23	50767	Pin	1				X
24	01010	Rotor Spacer	1		X		
25	01013	Cylinder	1			X	
26	01011	Blade (4/pkg.)	1	X			
27	01120	Rotor	2				X
28	01244	Bearing Plate	1				X
29	01015	Bearing	1		X		
30	95558	Retaining Ring	1	D			
31	30420	Housing	1				X
32	01477	Valve Stem	2		X		
33	95730	O-Ring	1				X
34	01024	O-Ring	1				X
35	01247	Speed Regulator Assembly	1		X		
36	01090	Throttle Lever	1				X
	01089	Safety Throttle Lever	1			X	
37	01017	Pin	1		X		
38	01464	Seal	1		X		
39	01472	Tip Valve	1		X		
40	01438	Spring	1		L		
41	53190	Block Plate	1				X
42	96065	O-Ring	1		L		
43	01494	Inlet Adapter	1				X

Note: Please refer to pages 8-10 of tool manual for specific part number.

Dynafile® Standard Contact Arm Assemblies

Part Number	Abrasive Belt Size	Contact Wheel Description	Comments	Contact Wheel Assembly	Contact Wheel Only	Bearing (2) Req.	Shaft
11178	1/2" x 34"	5/16" Dia. x 3/8" W Steel	9" Reach	11068	11067	11051	11054
11179	1/2" x 34"	5/8" Dia. x 3/8" W Rubber	9" Reach	11078	11077	11052	11054
11212	1/4" x 24"	5/16" Dia. x 1/8" W Steel	1/4" W Platen	11066	11065	11051 (1)	11056
11213	1/2" x 24"	5/16" Dia. x 3/8" W Steel	1/2" W Platen	11068	11067	11051	11054
11214	1/2" x 24"	7/16" Dia. x 3/8" W Rubber	1/2" W Platen	11070	11069	11051	11054
11215	1/4" x 24"	7/16" Dia. x 1/8" W Brass	1/4" W Platen	11072	11071	11052 (1)	11053
11216	1/4" x 24"	5/8" Dia. x 1/8" W Rubber	1/4" W Platen	11074	11073	11052 (1)	11053
11217	1/2" x 24"	1/2" Dia. x 3/8" W Steel	1/2" W Platen	11076	11075	11052	11054
11218	1/2" x 24"	5/8" Dia. x 3/8" W Rubber	1/2" W Platen	11078	11077	11052	11054
11219	1/4" or 1/2" x 24"	1" Dia. x 3/8" W Radiused Rubber	No Platen	11080	11079	11052	11054
11228	1/2" x 24"	5/8" Dia. x 3/8" W Rubber	H.D. Version of 11218 Arm	11078	11077	11052	11054
11231	1/2" x 24"	3/4" Dia. x 1/2" W Rubber	1/2" W Platen	11084	11083	11052	11055
11232	1/8" or 1/4" x 24"	1" Dia. x 3/8" W Tapered Urethane	No Platen	11086	11085	11052	11054
11234	1/2" x 34"	1" Dia. x 3/8" W Radiused Rubber	Double Burrer Arm	11080 (2)	11079 (2)	11052	N/A
11237	5/16" x 24"	5/16" Dia. x 1/8" W Steel	Polish Turbine Blades	11066	11065	11051 (1)	11053
11238	1/2" x 24"	1/4" Dia. x 3/8" W Steel	Polish Turbine Blades	11051 (3) and 11054	11051 (3)	N/A	11054
11239	1/2" x 24"	5/16" Dia. x 3/8" W Steel	H.D. Version of 11213 Arm	11068	11067	11051	11054
11240	1/2" x 34"	5/8" Dia. x 3/8" W Rubber	1/2" W Platen - 9" Reach	11078	11077	11052	11054
11241	1/4" x 34"	5/8" Dia. x 1/8" W Rubber	1/4" W Platen - 9" Reach	11074	11073	11052 (1)	11053
11243	1/2" x 24"	3/4" Dia x 1/2" W Rubber	H.D. Version of 11231 Arm	11084	11083	11052	11055
11244	1/2" x 44"	5/8" Dia. x 3/8" W Rubber	1/2" W Platen - 14" Reach	11078	11077	11052	11054
11245	1/4" x 44"	5/8" Dia. x 1/8" W Rubber	1/4" W Platen - 14" Reach	11074	11073	11052 (1)	11053
11254	1/2" or 1/4" x 34"	4-3/4" or 2-1/8" Dia. to 1/4" or 1/2" W	Grind in Deep Narrow Slots	Variable	Variable	11013 (1)	95162
11255	1/2" x 34"	5/8" Dia. x 3/8" W Rubber	Deburr I.D. 1" to 4"	11078	11077	11052	11054
11257	1/2" Wide	5/16" Dia. x 3/8" W Steel or 5/8" Dia. x 3/8" W Rubber	"Spear-Arm" - Specify length up to 32"	11068 Steel 11078 Rubber	11067 Steel 11077 Rubber	11051 Steel 11052 Rubber	11054
11258	1/2" x 24"	1/2" Dia. x 3/8" W Steel and 5/8" Dia. x 3/8" W Rubber	Platen Between 2 Contact Wheels	11076 Steel 11078 Rubber	11075 Steel 11077 Rubber	11052 (4)	11054 (2)
11261	1/2" x 24"	5/8" Dia. x 3/8" W Rubber	"Banana Arm" - For in-line scratch pattern.	11078	11077	11052	11054
11262	1/2" x 24"	5/8" Dia. x 3/8" W Rubber	"Offset Arm" - Contact wheel is offset to prevent gouging.	11078	11077	11052	11054
11297	1/2" x 24"	5/8" Dia. x 3/8" W Rubber	Contains two 11395 Guide Wheels. Prevents undercutting.	11090	11077	11052	95610

See next page for a complete guide to contact arms. Also see page 11 for contact arm disassembly and assembly instructions.

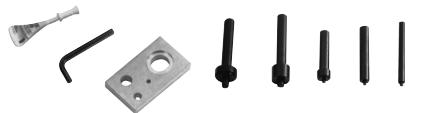

11288 Dynafile Contact Arm and Idler Wheel Repair Kit

- Contains special tools to assist in the replacement of contact wheels and bearings.

Dynafile® Standard Contact Arms

Standard Contact Arms allow for a 4" workable reach.

11212

File round openings as small as 7/16".
45 PSIG maximum.



Belt Size: 1/4" W x 24" L.

11066 Contact Wheel: 5/16" diameter x 1/8" wide, steel.

11034 Platen: 1/4" wide.

11213

See 11239 for heavy-duty version.
45 PSIG maximum.



Belt Size: 1/2" W x 24" L.

11068 Contact Wheel: 5/16" diameter x 3/8" wide, steel.

11027 Platen: 1/2" wide.

11214

Work on contact wheel or Dynapad®.
45 PSIG maximum.

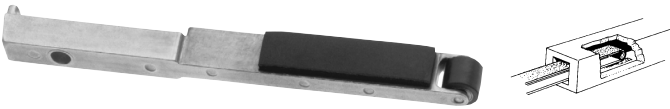

Belt Size: 1/2" W x 24" L.

11070 Contact Wheel: 7/16" diameter x 3/8" wide, rubber.

11025 Platen: 1/2" wide.

11215

Enter 1/2" x 1/2" openings.



Belt Size: 1/4" W x 24" L.

11072 Contact Wheel: 7/16" diameter x 1/8" wide, brass.

11034 Platen: 1/4" wide.

11216

Enter 5/16" x 3/4" openings.



Belt Size: 1/4" W x 24" L.

11074 Contact Wheel: 5/8" diameter x 1/8" wide, rubber.

11032 Platen: 1/4" wide.

11217

Enter channels as narrow as 9/16".



Belt Size: 1/2" W x 24" L.

11076 Contact Wheel: 7/16" diameter x 3/8" wide, steel.

11027 Platen: 1/2" wide.

11218

Standard arm on model 14000.
See 11228 for heavy-duty version.

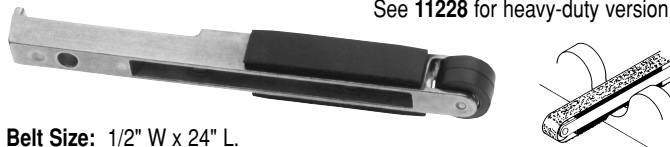

Belt Size: 1/2" W x 24" L.

11078 Contact Wheel: 5/8" diameter x 3/8" wide, rubber.

11025 Platen: 1/2" wide.

11219

No platen due to offset design.
Grind radiuses, slack polish.



Belt Size: 1/4" or 1/2" W x 24" L.

11080 Contact Wheel: 1" diameter x 3/8" wide, radiused rubber.

No Platen

11228 Heavy-Duty Steel

Optional **11028 Steel Platen**
available for grinding.



Belt Size: 1/2" W x 24" L.

11078 Contact Wheel: 5/8" diameter x 3/8" wide, rubber.

11025 Platen: 1/2" wide.

11231

See 11243 for heavy-duty version.

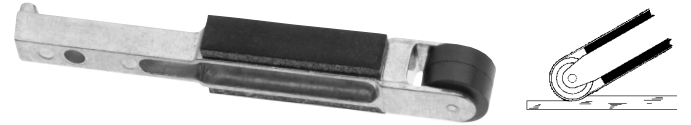

Belt Size: 1/2" W x 24" L.

11084 Contact Wheel: 3/4" diameter x 1/2" wide, rubber.

11135 Platen: 1/2" wide.

11232 For 1/8" Wide Belts

V-Tapered

No platen due to offset design.
Grind corners, strap polish.

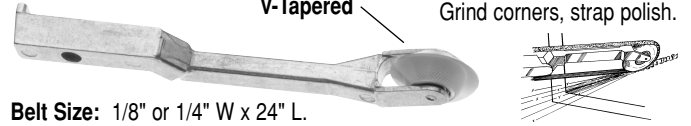

Belt Size: 1/8" or 1/4" W x 24" L.

11086 Contact Wheel: 1" diameter x 3/8" wide, tapered urethane.

No Platen.

11239 Heavy-Duty Steel

Grind in narrow areas.
45 PSIG maximum.



Belt Size: 1/2" W x 24" L.

11068 Contact Wheel: 5/16" diameter x 3/8" wide, steel.

11027 Platen: 1/2" wide.

11243 Heavy-Duty

Grind over contact wheel or Dynapad®.

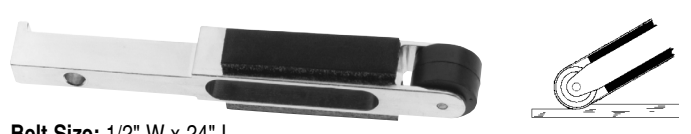

Belt Size: 1/2" W x 24" L.

11084 Contact Wheel: 3/4" diameter x 1/2" wide, rubber.

11135 Platen: 1/2" wide.

11262 "Offset Arm"

For flat grinding using platen at or near corners
and edges of large radius round. Contact wheel
is offset to prevent gouging.



Belt Size: 1/2" W x 24" L.

11078 Contact Wheel: 5/8" diameter x 3/8" wide, rubber.

11026 Platen: 1/2" wide.

Dynaflex® Specialized Contact Arms

Designed to solve tough production problems.

11237 and 11238 Turbine Blade Arms

45 PSIG maximum.



- 11237: 1/4" wide x 24" long belts.
- 11066 Contact Wheel: 5/16" dia. x 1/8" wide steel wheel.
- 11238: 1/2" wide x 24" long belts.
- Contact Wheel: 1/4" dia. x 3/8" wide steel wheel.

11255 Cross-Bow Arm

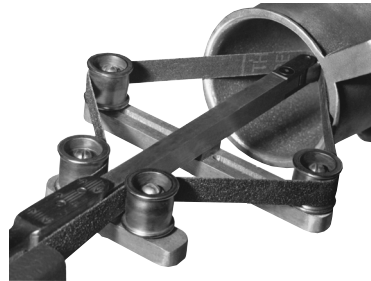

- I.D. polishing or deburring with one 180° wrist turn.
- Deburr leading radius of 1" to 4" round openings.

Belt Size: 1/2" W x 34" L.

11234 Double-Burrer Arm



- Deburs both edges of workpiece simultaneously.
- Contact wheels adjust for material 1/8" to 5/8" thick.

Belt Size: 1/2" wide x 34" long.
11080 Contact Wheels: 1" diameter x 3/8" wide, rubber.

11257, 11178 and 11179 Spear Arms



11257: Custom-made. Specify usable length up to 32". Specify 11068 - 5/16" diameter steel or 11078 - 5/8" diameter rubber contact wheel.

11178: Has 9" reach with 11068 - 5/16" diameter steel contact wheel.
Belt Size: 1/2" W x 34" L (45 PSIG Max.).

11179: Has 9" reach with 11078 - 5/8" diameter rubber contact wheel.
Belt Size: 1/2" W x 34" L.

11240, 11241, 11244 and 11245 Extra-Length Arms

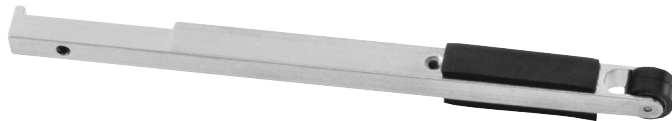

9" Workable Reach:

11240 Arm:
Belt Size: 1/2" W x 34" L belts.
11078 Contact Wheel:
5/8" dia. x 3/8" wide, rubber.

11241 Arm:
Belt Size: 1/4" W x 34" L belts.
11074 Contact Wheel:
5/8" dia. x 1/8" wide, rubber.

14" Workable Reach:

11244 Arm:
Belt Size: 1/2" W x 44" L belts.
11078 Contact Wheel:
5/8" dia. x 3/8" wide, rubber.

11245 Arm:
Belt Size: 1/4" W x 44" L belts.
11074 Contact Wheel:
5/8" dia. x 1/8" wide, rubber.

11258 Stroke Sander Arm

Blend stainless steel.

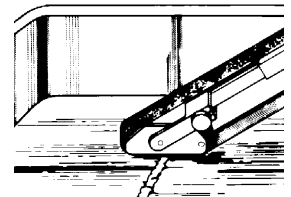

Belt Size: 1/2" W x 24" L.
11078 Contact Wheel: 5/8" diameter x 3/8" wide, rubber.
Platen: 1/2" W x 7/8" L.

11254 Big Wheel Arm

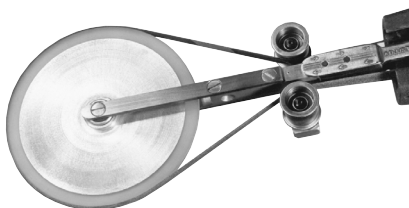

- Grinds and polishes deep slots or narrow grooves.
- 1/4" to 1/2" wide wheels, 2-1/8" to 4-3/4" diameter (specify size).

Belt Size: 1/4" to 1/2" W x 34" L.

11253 Arms (specify width)

11377 Contact Wheel: 2-1/8" dia. x 1/2" wide, urethane.
11378 Contact Wheel: 2-1/8" dia. x 1/4" wide, urethane.

11254 Arms (specify width)

11375 Contact Wheel: 4-3/4" dia. x 1/2" wide, urethane.
11375 Contact Wheel: 4-3/4" dia. x 1/4" wide, urethane.

11297 Guide-Cut Arm



- Guide wheels prevent undercutting.
- Removes raised material within .020" or less.
- Use 60 to 80 grit abrasive belts with this arm.

Belt Size: 1/2" W x 24" L, 60 to 80 grit.
11090 Contact Wheel: 5/8" diameter x 3/8" wide rubber.

Contact Arm Assembly/Disassembly Instructions

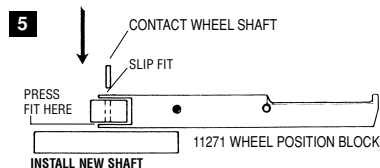
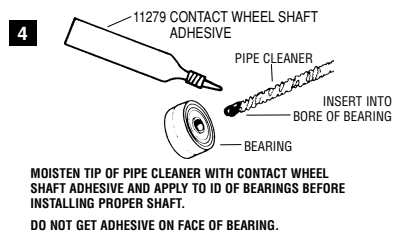
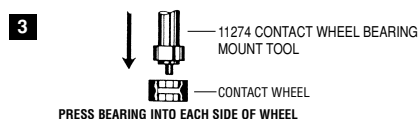
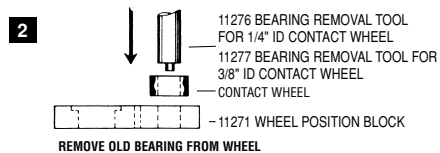
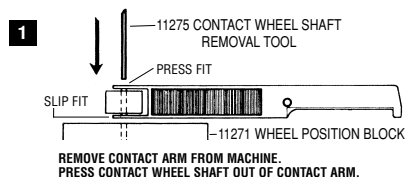

Abrasive Belt Exchange Instructions



With your thumb, pull and slide guard open in a clockwise direction.



Form a loop in belt keeping the belt splice between fingers as shown in photo above. Slip lower loop of belt under the drive wheel.



Depress idler arm lever and pull belt toward the contact wheel.



Slip belt over contact wheel. Release idler arm lever. Operate on the contact wheel or on the return side of the belt.



Completely close the guard.

Reference Contact Information

- American National Safety Institute – ANSI**
24 West 43rd Street
Fourth Floor
New York, NY 10036
Tel: 1 (212) 642-4900
Fax: 1 (212) 398-0023
- Government Printing Office – GPO**
Superintendent of Documents
Attn. New Orders
P.O. Box 371954
Pittsburgh, PA 15250-7954
Tel: 1 (202) 512-1803
- European Committee for Standardization**
Rue de Stassart 36
B - 1050 Brussels, Belgium

Optional Accessories



Composite Dynaswivel®

Swivels 360° at two locations which allows an air hose to drop straight to the floor, no matter how the tool is held.

- **94300:** 1/4" NPT.



50971 Lock Ring Tool

- Lock Ring Tool has a 3/8 in. square socket for use with 3/8 in. drive; breaker bar, ratchet head, or torque wrenches.



96211 Bearing Removal Tool

- This tool is designed to pass through the I.D. of the bearing plate and push against the I.D. of the bearing.



96241 Bearing Press Tool

- This tool is designed to safely press a bearing into a bearing plate and onto a shaft.



95600 Motor Tune-Up Kit:

- Includes assorted parts to help maintain and repair motor.



Dynabrade Air Lube

- Formulated for pneumatic equipment.
- Absorbs up to 10% of its weight in water.
- Prevents rust and formation of sludge.
- Keeps pneumatic tools operating longer with greater power and less down time.

95842: 1 pt. (473 ml)

95843: 1 gal. (3.8 L)



11288 Dynaflex Contact Arm and Idler Wheel Repair Kit

- Contains special tools to assist in the replacement of contact wheels and bearings.

Visit Our Web Site: www.dynabrade.com

Email: Customer.Service@Dynabrade.com



DYNABRADE, INC., 8989 Sheridan Drive • Clarence, NY 14031-1490 • Phone: (716) 631-0100 • Fax: 716-631-2073 • International Fax: 716-631-2524
DYNABRADE EUROPE S.à.r.l., Zone Artisanale • L-5485 Wormeldange—Haut, Luxembourg • Telephone: 352 76 84 94 1 • Fax: 352 76 84 95 1

©DYNABRADE, INC., 2002

PRINTED IN USA