

Dynabelter[®] Accu-Grinder

For 1" Wide Abrasive Belts

Model 11486 - Heavy Duty

PD13.31
October, 2013
Supersedes PD01.05

For Serial No. P-AG1AW1085 and Higher

! WARNING

Always operate, inspect and maintain this tool in accordance with the Safety Code for portable air tools (ANSI B186.1) and any other applicable safety codes and regulations. Please refer to Dynabrade's Warning/Safety Operating Instructions for more complete safety information.

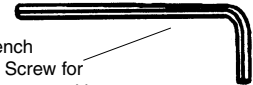
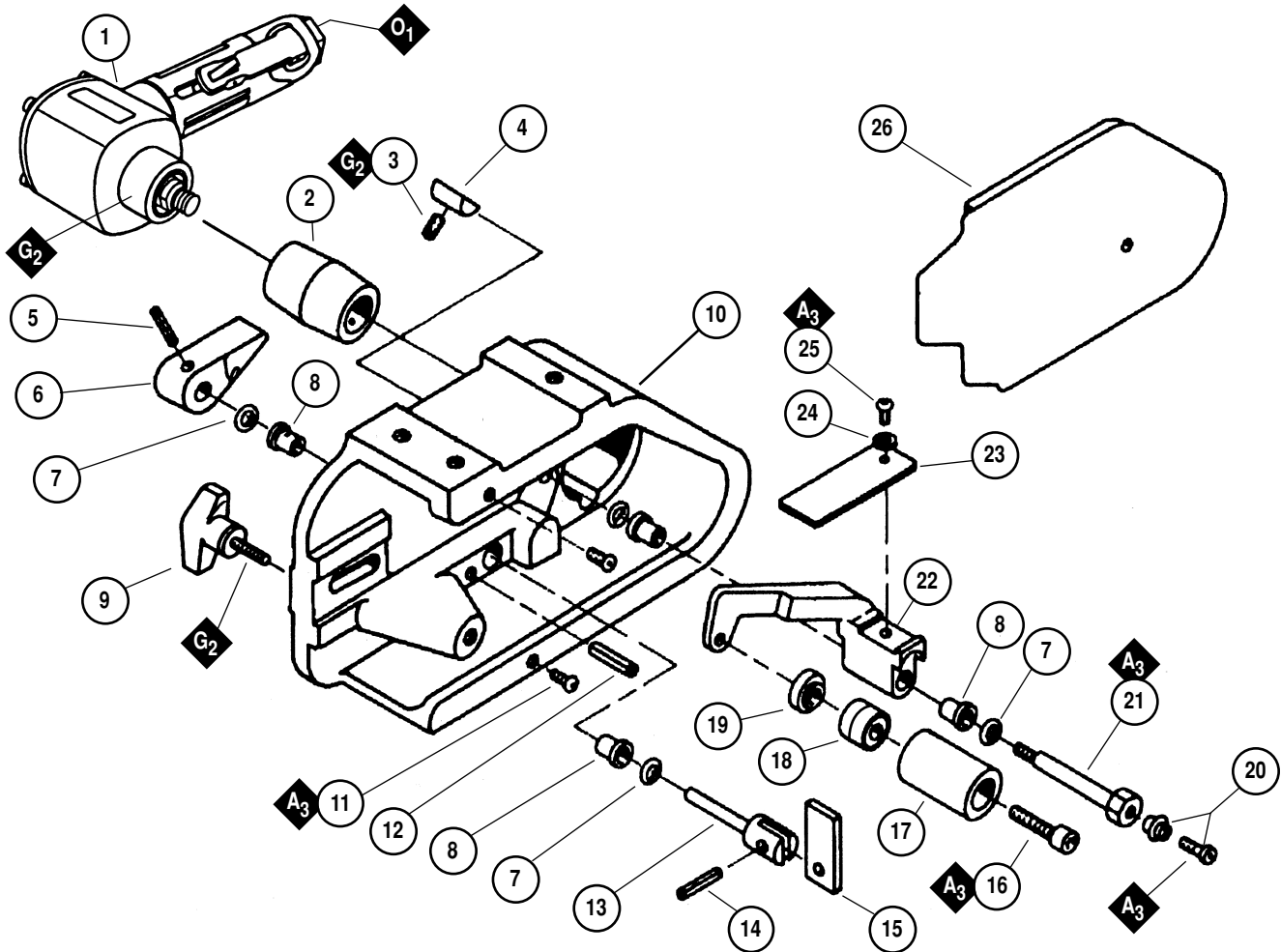

95048 Wrench
Fits 95392 Screw for
adjusting motor position.

Index Key

No. Part # Description

1	07100	Air Motor	10	11516	Housing	19	11017	Spacer
2	11518	Drive Wheel	11	95207	Screw (2)	20	11577	Button Latch Assy.
3	95392	Set Screw	12	95454	Pin	21	11575	Tension Lever Screw
4	11801	Motor Lock	13	11547	Shaft	22	11517	Idler Arm
5	95240	Roll Pin	14	95216	Pin	23	11539	Tension Spring
6	11551	Belt Tension Lever	15	11545	Tension Wiper	24	95146	Washer
7	95226	O-Ring (4)	16	95239	Screw	25	95235	Screw
8	11519	Flange Bearing (4)	17	11531	Idler Wheel	26	11592	Cover Guard
9	95419	Knob (Incl. 95417 Washer)	18	11016	Bearing (2)			

KEY	
O	Oil: O ₁ = Air Lube
G	Grease: G ₂ = Loctite #771
A	Adhesive: A ₁ = Loctite #609 A ₂ = Loctite #271 A ₃ = Loctite #243 A ₆ = Loctite #380 A ₈ = Loctite #567
T	Torque: N•m x 8.85 = In. - lbs.

Note: To order replacement parts specify the model and serial number of your machine.

*See page 2 for 07100 Motor Assembly and Standard Contact Arm Assembly.

See page 3 for Important Operating/Maintenance and Safety Instructions before operating this tool.

Air Motor 07100 (Heavy-Duty)

Powers Model 11486 Dynabelter® Accu-Grinder (Includes 11518 Drive Wheel)

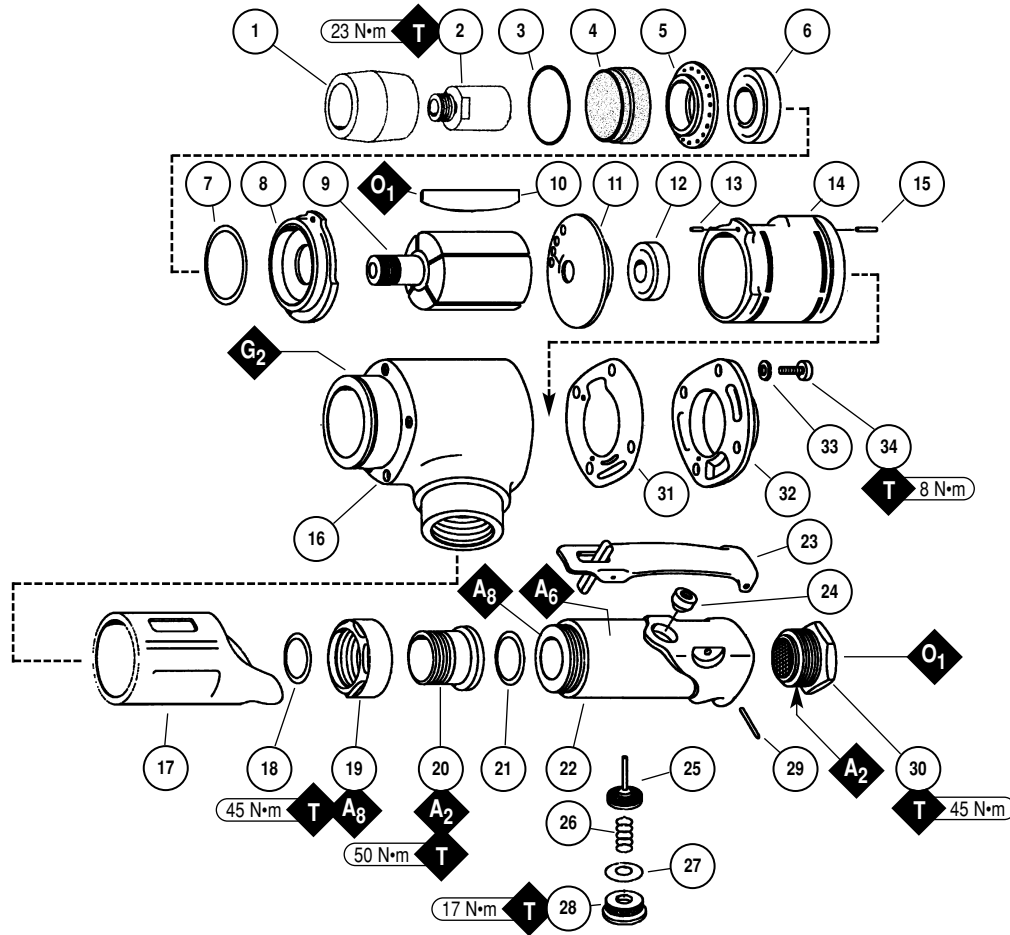

Index Key

1	11518	Drive Wheel
2	02553	Spindle Adapter
3	95584	O-Ring
4	01674	Silencer
5	07153	Air Control Ring
6	01036	Bearing
7	01277	Shim Pack (3/Pkg.)
8	07119	Bearing Plate
9	07103	Rotor
10	07107	Blade (5/Pkg.)
11	07114	Bearing Plate
12	01007	Bearing
13	01673	Guide Pin
14	07118	Cylinder
15	01775	Guide Pin
16	07130	Housing
17	07136	Grip
18	02658	Packing
19	02631	Nut
20	02626	Adj. Housing
21	01746	O-Ring
22	07141	Valve Body Assembly (Incl. 07142 Bushing)
23	01089	Safety Lock Lever
24	07142	Bushing
25	07168	Valve Stem Assembly
26	07145	Spring
27	07146	Packing
28	07147	Plug
29	01017	Pin
30	01660	Inlet Bushing
31	07129	Gasket
32	07122	Cap
33	01791	Washer (4)
34	01790	Screw (4)

KEY	
O	Oil: O ₁ = Air Lube
G	Grease: G ₂ = Loctite #771
A	Adhesive: A ₂ = Loctite #271 A ₆ = Loctite #380 A ₈ = Loctite #567
T	Torque: N·m x 8.85 = In. - lbs.

11717 Adjust-A-Wheel™ contact arm assembly with 1" wide x 2" diameter, 90 durometer, standard serrated 11617 contact wheel (included in contact wheel assembly 11618). For additional contact wheel assemblies, see reverse side.

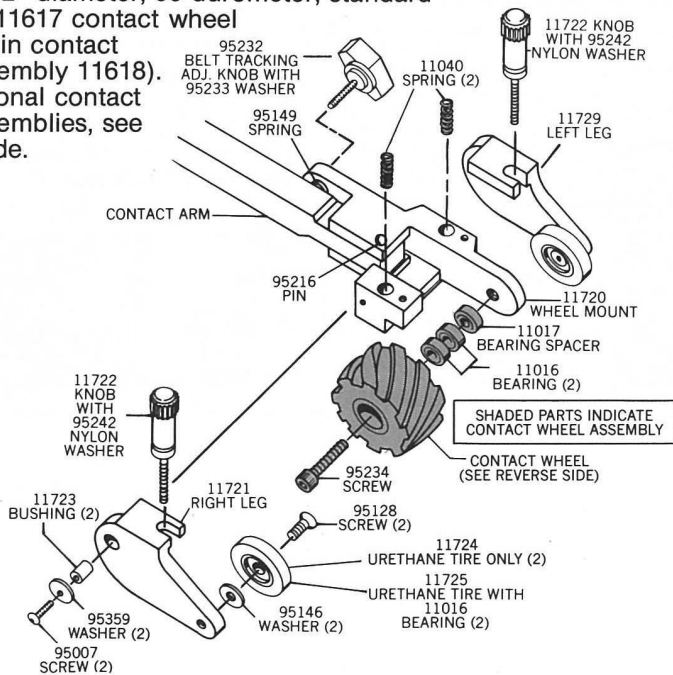

11705 Pressure Bar Assembly

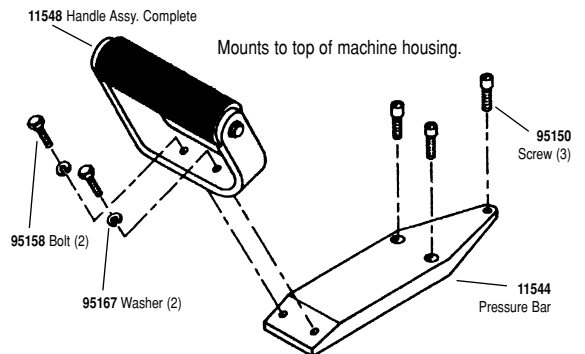

Back Support Wheels



Important Operating, Maintenance and Safety Instructions

Carefully read all instructions before operating or servicing any Dynabrade® Abrasive Power Tool.

Warning: Hand, wrist and arm injury may result from repetitive work motion and overexposure to vibration.

Operating Instructions:

Warning: Eye, face, respiratory, sound and body protection must be worn while operating power tools. Failure to do so may result in serious injury or death. Follow safety procedures posted in workplace.

1. With power source disconnected from tool, securely position abrasive belt on tool (see abrasive belt/contact arm change instructions).
2. Connect power source to tool. Be careful **not** to depress throttle lever in the process.
3. Check tool speed with tachometer. If tool is operating at a higher speed than the RPM marked on the tool or operating improperly, the tool should be serviced to correct the cause before use.
4. Always work off the return side of the abrasive belt. This will ensure superior tracking and less down time of machine.

Abrasive Belt/Contact Arm Change Instructions:

To Change Belt:

1. Disconnect power source.
2. Remove **11592** Cover Guard.
3. Release **11551** Belt Tension Lever.
4. Pull belt backwards and to the left until belt is released from drive wheel.
5. Reverse process for applying new belt.
6. Connect power source.
7. Depress throttle lever to start motor and belt rotation.
8. Adjust belt tracking by turning **95232** Belt Tracking Knob on contact arm assembly to the left or right accordingly.

To Change Contact Arm Assembly:

1. Disconnect power source.
2. Remove **11592** Cover Guard.
3. Remove abrasive belt (see instructions).
4. Remove **95419** Rough Adjustment Knob.
5. Remove Contact Arm and replace with desired contact arm.
6. Replace **95419** Knob. Do not tighten knob at this point.
7. Replace abrasive belt.
8. With abrasive belt in proper position, push contact arm assembly forward until the contact wheel is tight against abrasive belt.
9. Tighten **95419** Knob.
10. Replace **11592** Cover Guard.
11. Reset **11551** Belt Tension Lever.
12. Connect power source and depress throttle lever to start motor and abrasive belt rotation.
13. Adjust belt tracking by turning **95232** Belt Tracking Knob on contact arm assembly to the left or right accordingly.

Maintenance Instructions:

Products offered by Dynabrade should not be converted or otherwise altered from original design without expressed written consent from Dynabrade, Inc. All Dynabrade rotary vane air tools must be used with a filter-regulator-lubricator to maintain all warranties.

1. Check tool speed regularly with a tachometer. If tool is operating at a higher speed than the RPM marked on the tool, the tool should be serviced to correct the cause before use.
2. Some silencers on air tools may clog with use. Clean and replace as required.
3. All Dynabrade rotary vane air motors should be lubricated with two drops of Dynabrade Air Lube (P/N **95842**: 1pt. 473ml.) every four hours of use.
4. It is strongly recommended that all Dynabrade rotary vane air tools be used with a Filter-Regulator to minimize the possibility of misuse due to unclean air, wet air or insufficient lubrication. Dynabrade recommends the following: **10681** Air Line Filter- Regulator-Lubricator — Provides accurate air pressure regulation, two-stage filtration of water contaminant's and micro-mist lubrication of pneumatic components. Operates 55 SCFM @ 100 PSIG has 1/2" NPT female ports.

Safety Instructions:

Products offered by Dynabrade should not be converted or otherwise altered from original design without expressed written consent from Dynabrade, Inc.



- **Important:** User of tool is responsible for following accepted safety codes such as those published by the American National Standards Institute (ANSI).
- **Warning:** Eye, face, respiratory, sound and body protection must be worn when operating power tools. Failure to do so may result in serious injury or death.
- Products offered by Dynabrade should not be converted or otherwise altered from original design without the expressed written consent of Dynabrade, Inc.
- Tool RPM rating must never exceed abrasive/accessory RPM rating, regardless of tools capacity.
- Operate machine for one minute before application to workpiece to determine if machine is working properly and safely before work begins.
- Always use proper guards. Make sure guards are in proper position, secure and in good repair.
- Always disconnect power supply before changing abrasive or making machine adjustments.
- Inspect abrasives for damage or defects prior to installation on tools. Make sure belts are mounted properly; check for proper tension and belt tracking.
- Please refer to Dynabrade's Warning/Safety Operating Instructions Tag for more complete safety information.

Machine Specifications

Model	Speed	Power	Sound	Air Consumption	Belt Size	Weight	Length	Height
11486	13,000 RPM	1.2 hp (895 W)	89 db(A)	58 SCFM (1,643 LPM)	1" W x 30" L	9.0 lb. (4.1 kg.)	22" (559 mm)	7" (178 mm)

Additional Specifications: Air Inlet Thread 1/2" NPT • Hose I.D. 1/2" (13 mm)
 Sound Level is the pressure measurement according to the method outlined in ISO regulation ISO-15744

Optional Accessories



Dynaswivel®

- Aluminum construction.
- 1/2" NPT.
- Swivels 360° at two locations which allows an air hose to drop straight to the floor.

Part No. 95462



Motor Tune-Up Kit

- Includes assorted parts to help maintain and repair motor.

Part No. 96011



Dynabrade Air Lube

- For pneumatic equipment.
- Absorbs up to 10% of its weight in water.
- Prevents rust and formation of sludge.

Part No. 95821 4 oz.

Part No. 95842 1 pt.

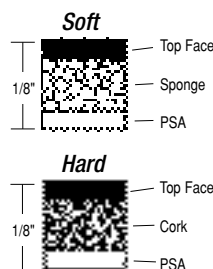

Dynapad®

- Mounts to tool contact arm to provide abrasive belt support.
- 1" W x 7" L and 1/8" Thick
- Includes 5 pads.

Part No. 11604 Soft (countours)

Part No. 11605 Hard (flats)

REFERENCE CONTACT INFORMATION

American National Standards Institute (ANSI)
 1899 L Street, NW, 11th Floor • Washington, DC 20036
 Tel: 1 (202) 293-8020

Compressed Air & Gas Institute (CAGI)
 1300 Sumner Ave. • Cleveland, OH 44115-2851
 Tel: 1 (216) 241-7333 • Fax: (216) 241-0105

Government Printing Office (GPO)
 Superintendent of Documents • Attn: New Orders
 P.O. Box 371954 • Pittsburgh, PA 15250-7954 • Tel: 1 (202) 512-1803

International Organization of Standards (ISO)
 Case postale 56 • CH-1211 Geneva 20
 Tel: + 41 22 749 01 11 • Fax: + 41 22 749 09 47

DYNABRADE, INC.

www.dynabrade.com

8989 Sheridan Drive • Clarence, NY 14031-1419 • Phone: 716-631-0100 • Fax: 716-631-2073 • International Fax: 716-631-2524
 ©DYNABRADE, INC., 2013 PRINTED IN USA PD13.31_10/13

