

DOTCO[®]

45-8442

**12L2384 Series
.5 HP Sander / File
20,000 RPM
4,550 SFPM**



12L2384-XX

Termination Codes

- B1- 3/4" X 18" Sanding Belt Attachment
- B2- 1/2" X 18" Sanding Belt Attachment
- B3- 1/4" X 18" Sanding Belt Attachment
- K1- 1 Each: 3/4", 1/2", 1/4" Attachments,
1/4" Collet Attachment,
Wrenches, and Sanding Belts
- 01- 1/4" Collet Chuck

IMPORTANT: Read and comply with safety and operating instructions contained in this manual.

For additional product information visit our website at <http://www.coopertools.com>

CooperTools
P.O. Box 1410
Lexington, SC 29071-1410

DOTCO
 12L2384 Series Sander / File

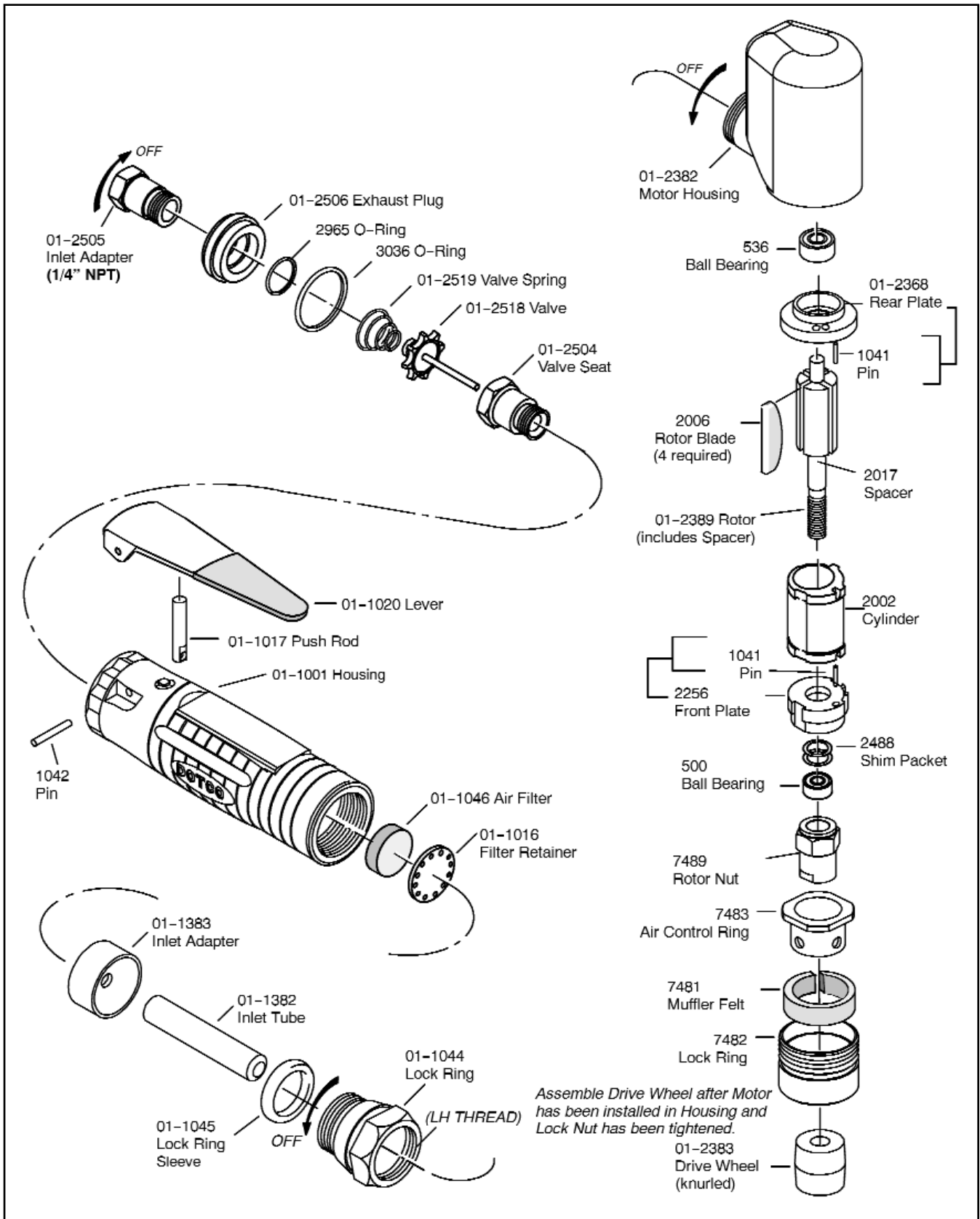

12L2384 Series Sander / File

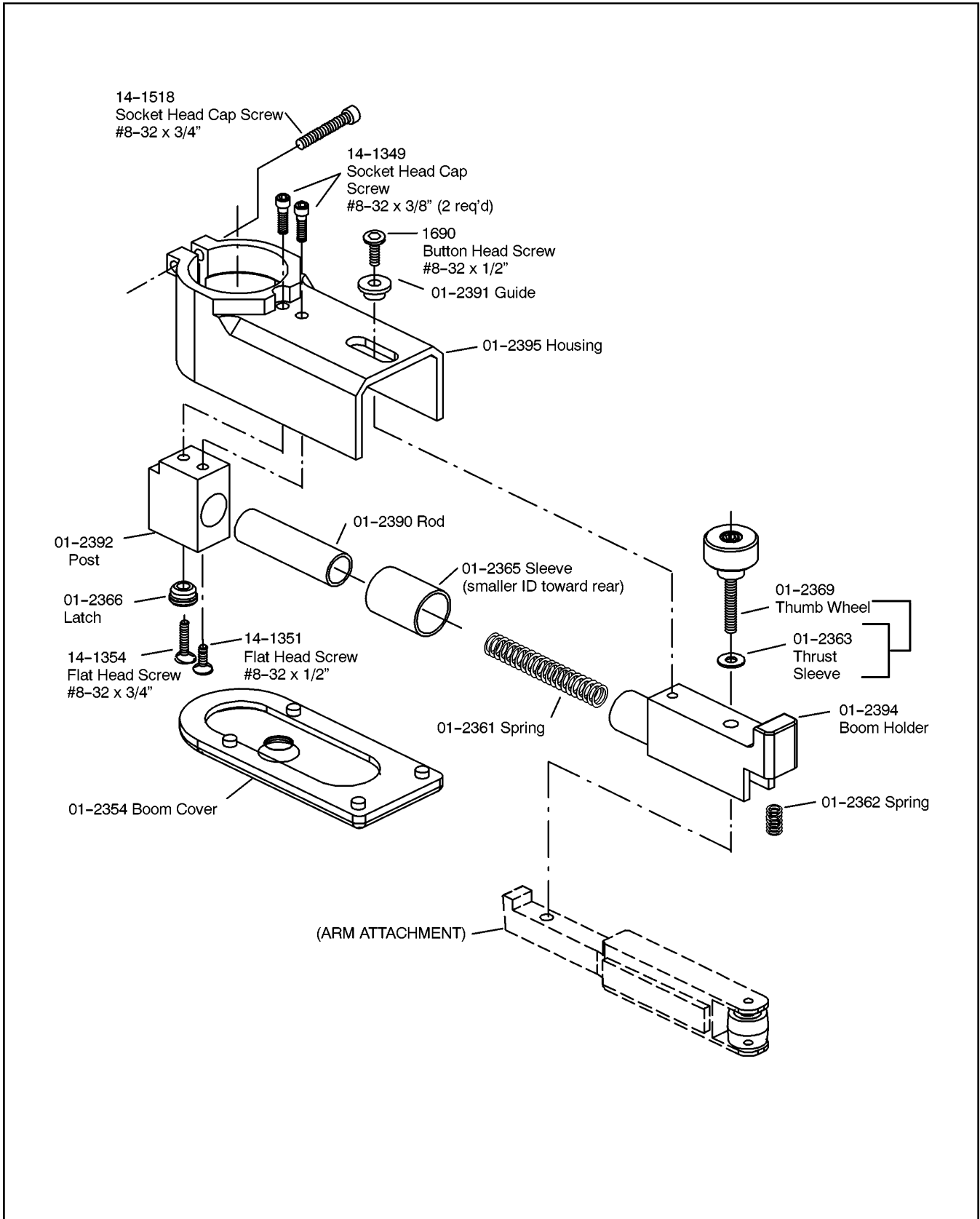

3/4" x 18" BELT ATTACHMENT

Complete Part Number 01-2360

TERMINATION: -B1

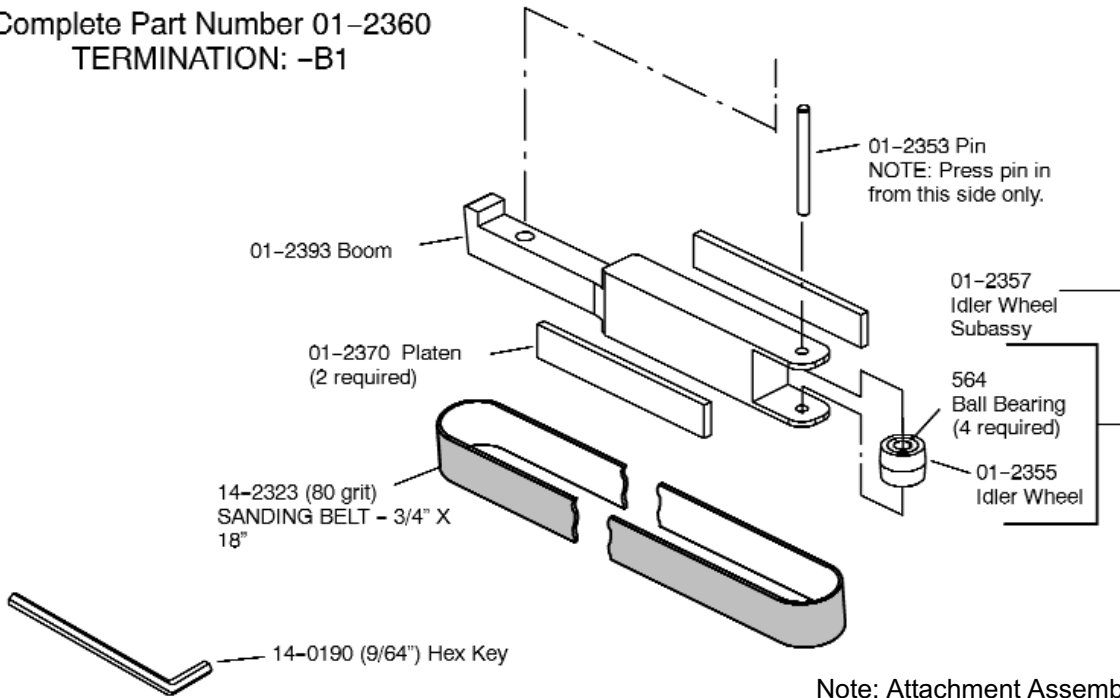

Note: Attachment Assemblies do not include sanding belt or hex wrench.

1/2" x 18" BELT ATTACHMENT

Complete Part Number 01-2358

TERMINATION: -B2

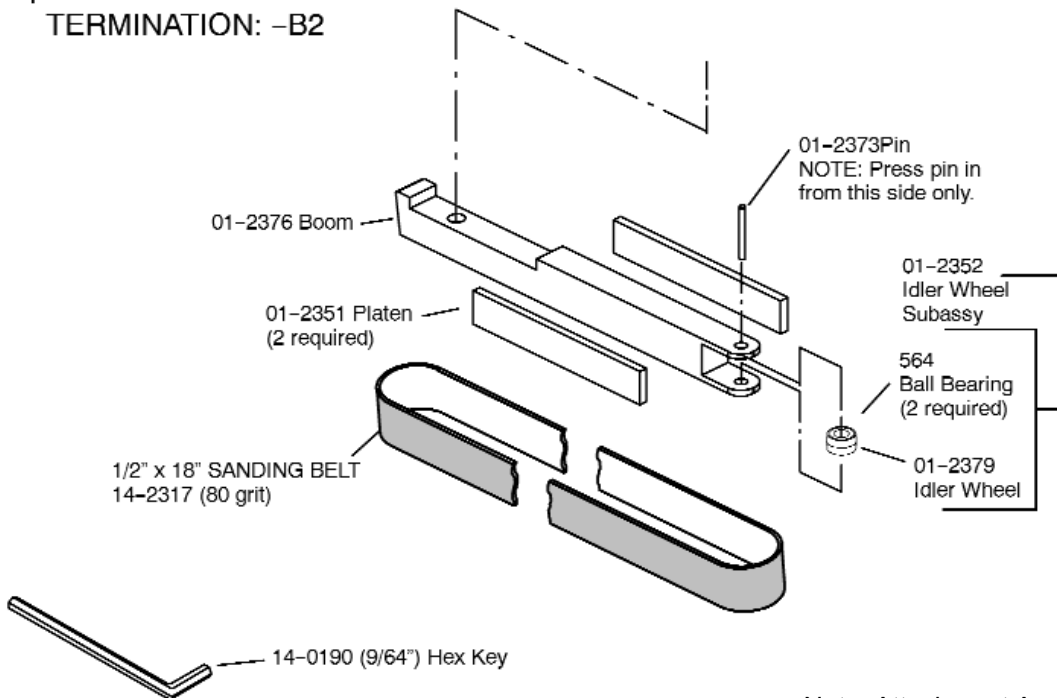

Note: Attachment Assemblies do not include sanding belt or hex wrench.

12L2384 Series Sander / File

1/4" x 18" BELT ATTACHMENT

Complete Part Number 01-2359

TERMINATION: -B3

NOTE: Attachment assembly does not include sanding belt or hex wrench.

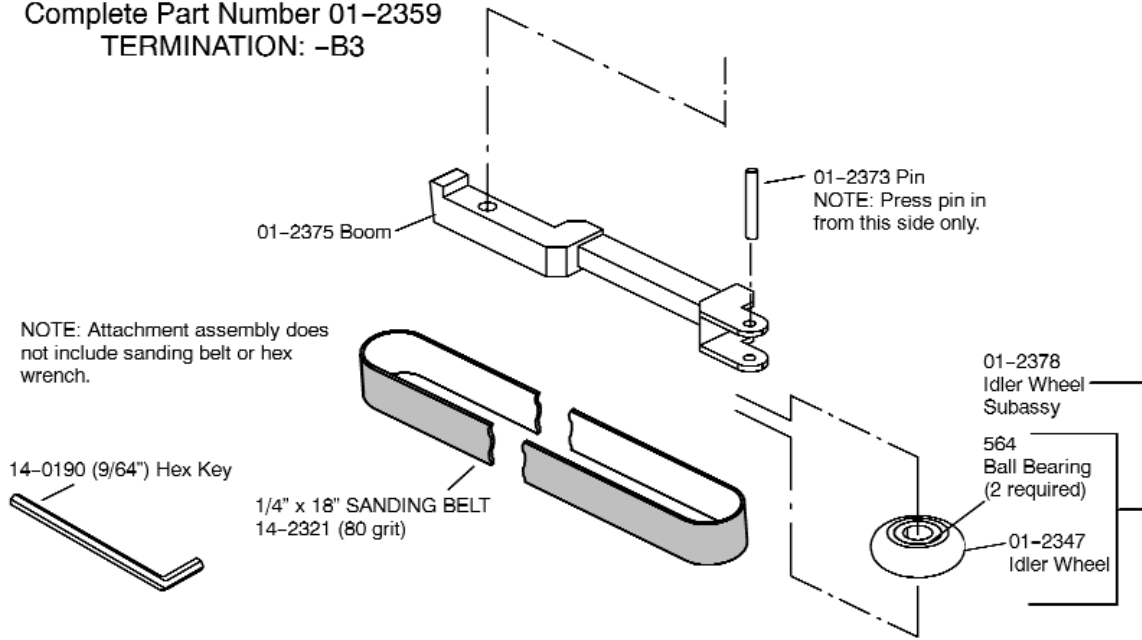

TERMINATION: -K1

- 3/4" X 18" BELT ATTACHMENT 01-2360
- 1/2" X 18" BELT ATTACHMENT 01-2358
- 1/4" X 18" BELT ATTACHMENT 01-2359

- 1/4" Sanding Belt (60 grit) 14-2320
- 1/4" Sanding Belt (80 grit) 14-2321
- 1/4" Sanding Belt (120 grit) 14-2322
- 1/2" Sanding Belt (60 grit) 14-2316
- 1/2" Sanding Belt (80 grit) 14-2317
- 1/2" Sanding Belt (120 grit) 14-2318
- 3/4" Sanding Belt (med. bear-tex) 14-2327
- 3/4" Sanding Belt (60 grit) 14-2326
- 3/4" Sanding Belt (80 grit) 14-2323

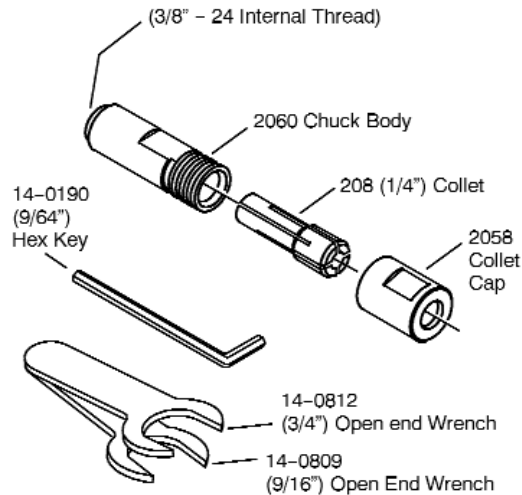

TERMINATION: -01

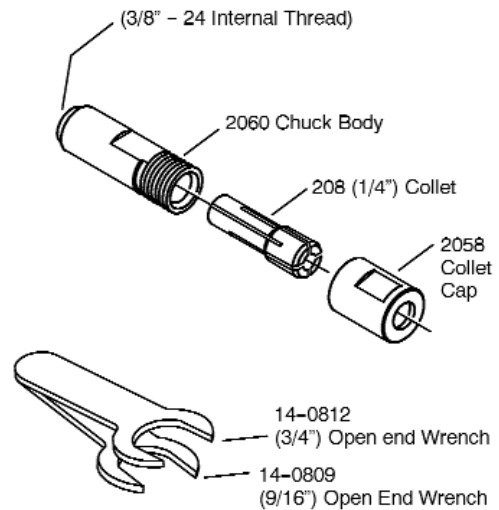

DOTCO

12L2384 Series Sander / File

RECOMMENDED SPARE PARTS LIST

These parts are suggested as a recommended inventory of spare parts. Where parts are small, low cost, or easily lost, then we recommend stocking 3 to 4 for every 10 tools. Other larger, lower wear or more expensive parts should be maintained as one (or one set) for every six to ten tools.

Part Number	Description	Quan Used Per Tool	Recommended Spare Pts	
			Per Tool	Per 10 Tools
ALL MODELS:				
3036	O-Ring	1	1	3
2965	O-Ring	1	1	3
536	Ball Bearing	1	1	2
01-2368	Rear Plate	1	1	2
2006	Rotor Blades	4	4	20
2002	Cylinder	1	1	2
2256	Front Plate	1	1	2
2488	Shim Packet	1	1	4
500	Ball Bearing	1	1	2
7481	Muffler Felt	1	1	3
01-1046	Air Filter	1	1	2
564	Ball Bearing	4	4	8
12L2384-K1				
2058	Collet Cap	1	1	2
208	1/4" Collet	1	1	2
01-2370	Cushioned Platen (3/4" Attachment)	2	2	4
01-2351	Cushioned Platen (1/2" Attachment)	2	2	4
12L2384-B1				
01-2370	Cushioned Platen	2	2	4
12L2384-B2				
01-2351	Cushioned Platen	2	2	4

Changing Contact Arm / Replacing Belt -

Disconnect air supply. Snap off boom cover. Pull back on boom holder and remove abrasive belt. Install new belt, replace cover, and track belt. OR: Remove thumb wheel. Contact arm can then be removed from boom holder. Install new contact arm in reverse manner making sure that the tab on the end of the contact arm faces down. Install belt, replace cover, and track belt.

Tracking Belt -

With tool running, rotate thumb wheel left or right until sanding belt runs straight.

Boom Housing Rotation Adjustment -

Loosen screw on side of boom housing with 9/64" hex wrench. Rotate boom housing to desired position. Tighten screw.

Conversion from Sander/File to Die Grinder -

Disconnect from air supply. Remove boom cover and abrasive belt using above directions. Loosen screw on side of boom housing. Pull boom housing from motor. Use a 3/16" hex wrench in the end of the motor shaft to prevent rotation. Using pliers with soft jaws, twist the drive wheel counterclockwise to remove. Hand thread the collet body onto the motor shaft. Using the 3/16" hex wrench to again stop the shaft rotation, use the 9/16" open end wrench to tighten the collet body onto the motor shaft. Install collet and use 9/16" open end wrench to secure collet body and use a 3/4" open end wrench to tighten collet cap.

 **CAUTION** NEVER TIGHTEN ANY COLLET INTO THE CHUCK WITHOUT THE ARBOR OF A MOUNTED POINT OR CARBIDE BUR INSTALLED THROUGH THE COLLET.



Cooper Power Tools

P.O. Box 1410
Lexington, SC 29071-1410
USA

Toll Free: 800-845-5629

Fax: 803-359-0822

www.cooperpowertools.com

Printed In USA