

**Parts Manual**  
**45-8214EN**  
PL30-1211  
12/14/2012

**DOTCO<sup>®</sup>**

**12-11 Series**  
Inline Extended Grinders



*For additional product information visit our website at <http://www.apextoolgroup.com>*

	<b>12</b>	<b>X</b>	<b>1</b>	<b>1</b>	<b>XX</b>	<b>-</b>	<b>36</b>	<b>XX</b>	<b>OH</b>												
<p><u>Tool Series</u> <b>12</b> = Ergo Grinder/Sander</p>																					
<p><u>Throttle Type</u> <b>L</b> = Locking Lever <b>S</b> = Locking Lever</p>																					
<p><u>Motor Size</u> <b>1</b> = 0.3 hp</p>																					
<p><u>Handle Style</u> <b>1</b> = Straight, Extended</p>																					
<p><u>Speed Options (RPM)</u></p> <table border="1"> <thead> <tr> <th>Front Exhaust (3" Extended)</th> <th>Rear Exhaust (3" Extended)</th> <th>Front Exhaust (5" Extended)</th> <th>Rear Exhaust (5" Extended)</th> </tr> </thead> <tbody> <tr> <td><b>00</b> = 28,000</td> <td><b>80</b> = 28,000</td> <td><b>01</b> = 28,000</td> <td><b>81</b> = 28,000</td> </tr> <tr> <td><b>11</b> = 25,000</td> <td></td> <td><b>12</b> = 25,000</td> <td></td> </tr> </tbody> </table>										Front Exhaust (3" Extended)	Rear Exhaust (3" Extended)	Front Exhaust (5" Extended)	Rear Exhaust (5" Extended)	<b>00</b> = 28,000	<b>80</b> = 28,000	<b>01</b> = 28,000	<b>81</b> = 28,000	<b>11</b> = 25,000		<b>12</b> = 25,000	
Front Exhaust (3" Extended)	Rear Exhaust (3" Extended)	Front Exhaust (5" Extended)	Rear Exhaust (5" Extended)																		
<b>00</b> = 28,000	<b>80</b> = 28,000	<b>01</b> = 28,000	<b>81</b> = 28,000																		
<b>11</b> = 25,000		<b>12</b> = 25,000																			
<p><u>Termination Code</u> <b>36</b> = 300 Series 1/4" Capacity Collet (3-piece)</p>																					
<p><u>Optional Collet (no extra cost)</u> <b>08</b> = 1/8" <b>14</b> = 7/32" <b>M6</b> = 6mm</p>																					
<p><u>Overhose Option (extra cost)</u> <b>OH</b> = Overhose (rear exhaust models only)</p>																					

## Description and Instructions

**Language Version:**

This Parts Manual is the ***“Original Instructions”*** intended for all persons who will use or repair these tools.

**Product Identification:**

Refer to the “Model Nomenclature” page in this document.

**Noise and Vibration:**

Refer to documents CE-1007DC and CE-1007TD.

**General Description:**

Air powered inline extended grinder.

**Intended Use:**

These air powered grinders are intended for material removal applications using carbide burs, mounted points, or mounted wheels. Use only for their designated purpose. Do not use as a hammer, lever or other improper usage that can cause tool damage and operator injury.

**Copyright protection:**

Apex Tool Group, LLC reserves the right to modify, supplement or improve this document or the product without prior notice. This document may not be reproduced in any way, shape or form, in full or parts thereof, or copied to another natural or machine readable language or to a data carrier, whether electronic, mechanical, optical or otherwise without the express permission of Apex Tool Group, LLC.

**General Safety:**

Refer to General Safety document, CE-2007 for general safety operating instructions for this equipment.

**Lubrication:**

Refer to lubrication document, PL65-LUB, for general lubrication instructions.

**CAUTION: Do not use lubricant substitutes. This could result in damage to the tool.**

**Dotco®**  
Front Exhaust Grinders

**“A”**

**Models**

- 12L1100-36
- 12L1101-36
- 12S1101-36
- 12L1111-36
- 12L1101-36

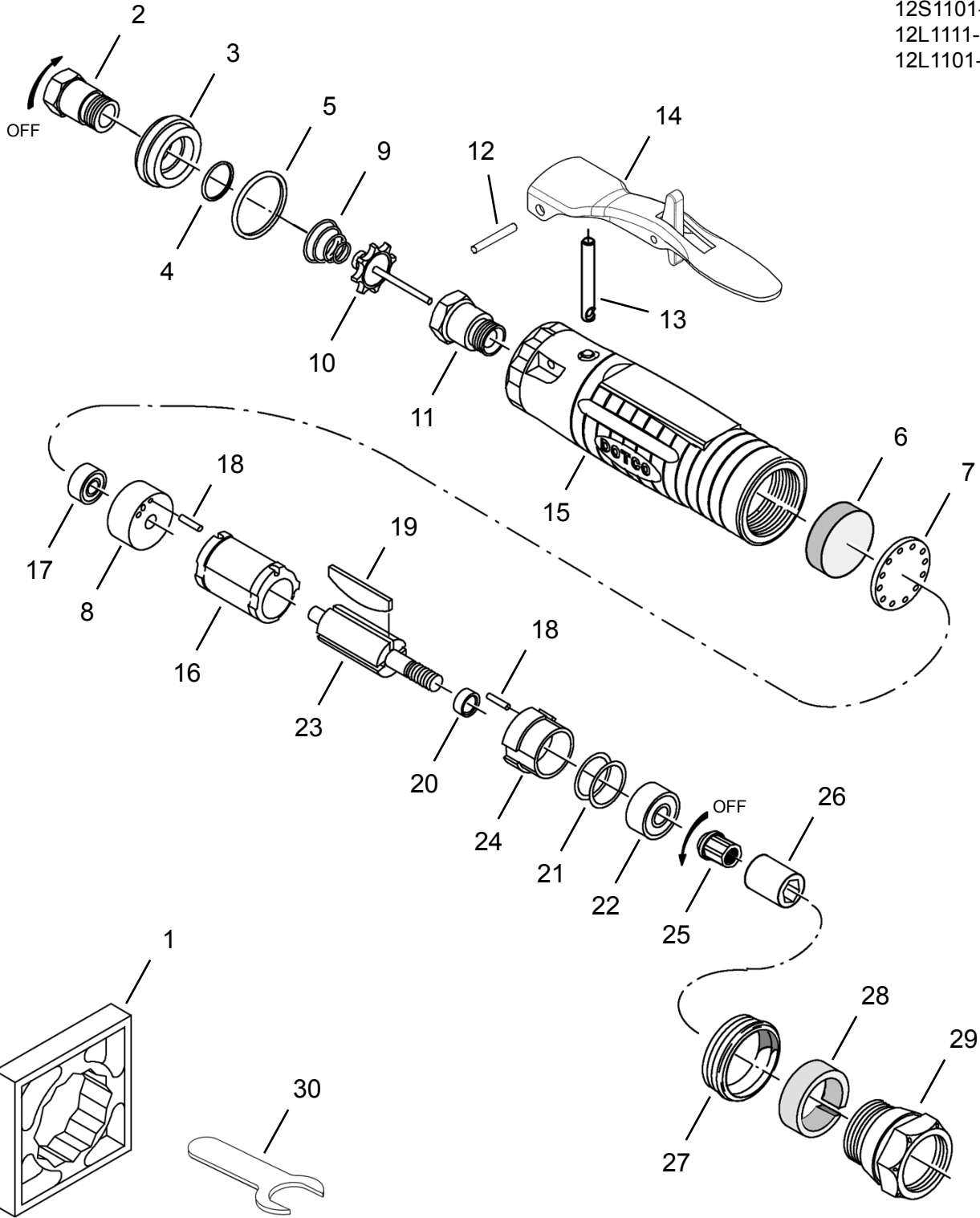

**Dotco®**  
Front Exhaust Grinders

**45-8214EN**  
12/14/2012

**Illustration "A"**

Ref	Number	#	X	EN	
				Description	
1	14-0851	1			Housing Wrench
2	01-2505	1	K1		Inlet Adapter
3	01-2506	1	K1		Exhaust Plug
4	2965	1	K1		O-Ring
5	3036PT	1	K1		O-Ring
6	01-1046	1	K1		Filter Disc
7	01-1016	1	K1		Filter Retainer
8	1003PT	1			Rear Plate (includes 1 Ref. 18)
9	01-2519	1	K2		Valve Spring
10	01-2518	1	K2		Valve
11	01-2504	1	K2		Valve Seat
12	1042	1	K2		Lever Pin
13	01-1017	1	K2		Push Rod
14	01-1267	1	K2		Lock-Off Lever Assembly
15	01-1001	1			Motor Housing
16	1002PT	1			Cylinder
17	504PT	1	K3		Ball Bearing
18	1041	2	K3		Pin
19	Table "A"	4	K3		Rotor Blade (*)
20	1017PT	1	K3		Spacer
21	1355	1	K3		Shim Packet
22	538PT	1	K3		Ball Bearing
23	1005S	1			Rotor
24	1064PT	1			Front Plate (includes 1 Ref. 18)
25	1708PT	1			Coupling Nut
26	02-1711	1			Coupling
27	01-1045	1	K4		Lock Ring Sleeve
28	01-1021	1	K1		Muffler Felt
29	01-1049	1	K4		Lock Ring
30	14-0807	1			Wrench (7/16")
	14-0811	1			Wrench (11/16")
<b>Repair Kits</b>					
K1	04-0144	1	1		Air Inlet Kit
K2	04-0143	1	1		Throttle Kit
K3	Table "A"	1	1		Motor Kit
K4	04-0145	1	1		Housing Kit
*	Table "A"	1	1		Rotor Blade Kit (contains 50 Rotor Blades)

(#) Quantity

(X) Included in Repair Kit (K#) or Recommended Spare Parts (quantity shown based on 1-5 tools in operation)

**Table "A"**

Ref.	Description	#	12(-)1100		#	12(-)1111	
			12(-)1101			12(-)1112	
19	Rotor Blade	4	1006PT		4	1906PT	
K3	Motor Kit	1	04-0042		1	04-0044	
*	Rotor Blade Kit	1	04-0031		1	04-0032	

**Models**  
12L1180-36  
12L1181-36  
12S1181-36

**“B”**

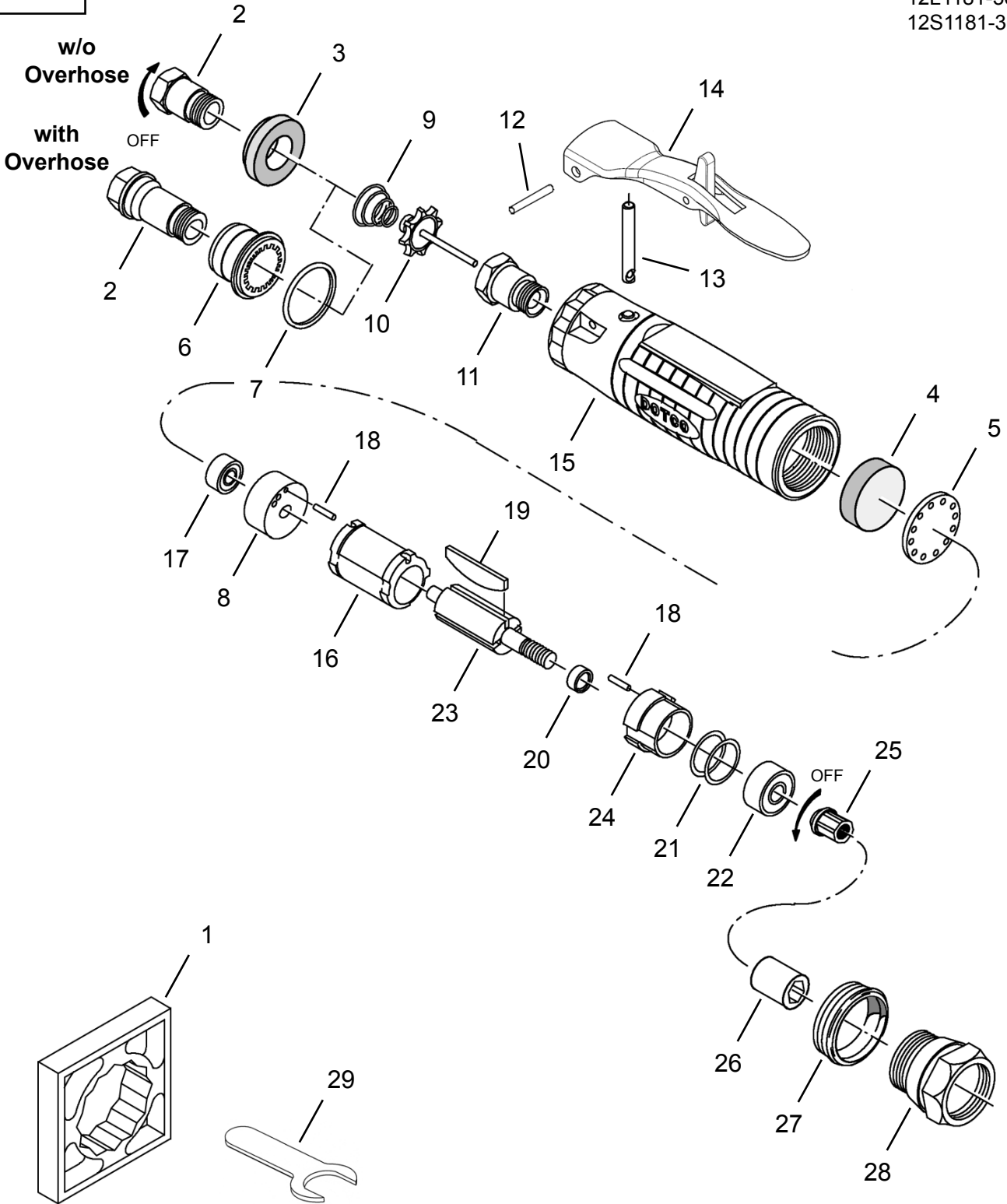

**Dotco®**  
Rear Exhaust Grinders

**45-8214EN**  
12/14/2012

**Illustration "B"**

Ref	Number	#	X	EN	
					Description
1	14-0851	1			Housing Wrench
2	01-2505	1	K5		Inlet Adapter (non Overhose version)
	01-1031	1	K5		Inlet Adapter (Overhose version)
3	01-2520	1	K5		Diffuser
4	01-1046	1	K5		Filter Disc
5	01-1016	1	K5		Filter Retainer
6	01-1032	1	K5		Muffler (Overhose version)
7	3036PT	1	K5		O-Ring (Overhose version)
8	1003PT	1			Rear Plate (includes 1 Ref. 18)
9	01-2519	1	K2		Valve Spring
10	01-2518	1	K2		Valve
11	01-2504	1	K2		Valve Seat
12	1042	1	K2		Lever Pin
13	01-1017	1	K2		Push Rod
14	01-1267	1	K2		Lock-Off Lever Assembly
15	01-1001	1			Motor Housing
16	1002PT	1			Cylinder
17	504PT	1	K3		Ball Bearing
18	1041	2	K3		Pin
19	1006PT	4	K3		Rotor Blade (*)
20	1017PT	1	K3		Spacer
21	1355	1	K3		Shim Packet
22	538PT	1	K3		Ball Bearing
23	1005S	1			Rotor
24	1064PT	1			Front Plate (includes 1 Ref. 18)
25	1708PT	1			Coupling Nut
26	02-1711	1			Coupling
27	01-1045	1	K6		Lock Ring Sleeve
28	01-1044	1	K6		Lock Ring
29	14-0807	1			Wrench (7/16")
	14-0811	1			Wrench (11/16")
<b>Repair Kits</b>					
K2	04-0143	1	1		Throttle Kit
K3	04-0042	1	1		Motor Kit
K5	04-0140	1	1		Air Inlet Kit (non Overhose version)
	04-0141	1	1		Air Inlet Kit (Overhose version)
K6	04-0146	1	1		Housing Kit
*	04-0031	1	1		Rotor Blade Kit (contains 50 Rotor Blades)

(#) Quantity

(X) Included in Repair Kit (K#) or Recommended Spare Parts (quantity shown based on 1-5 tools in operation)

“C”

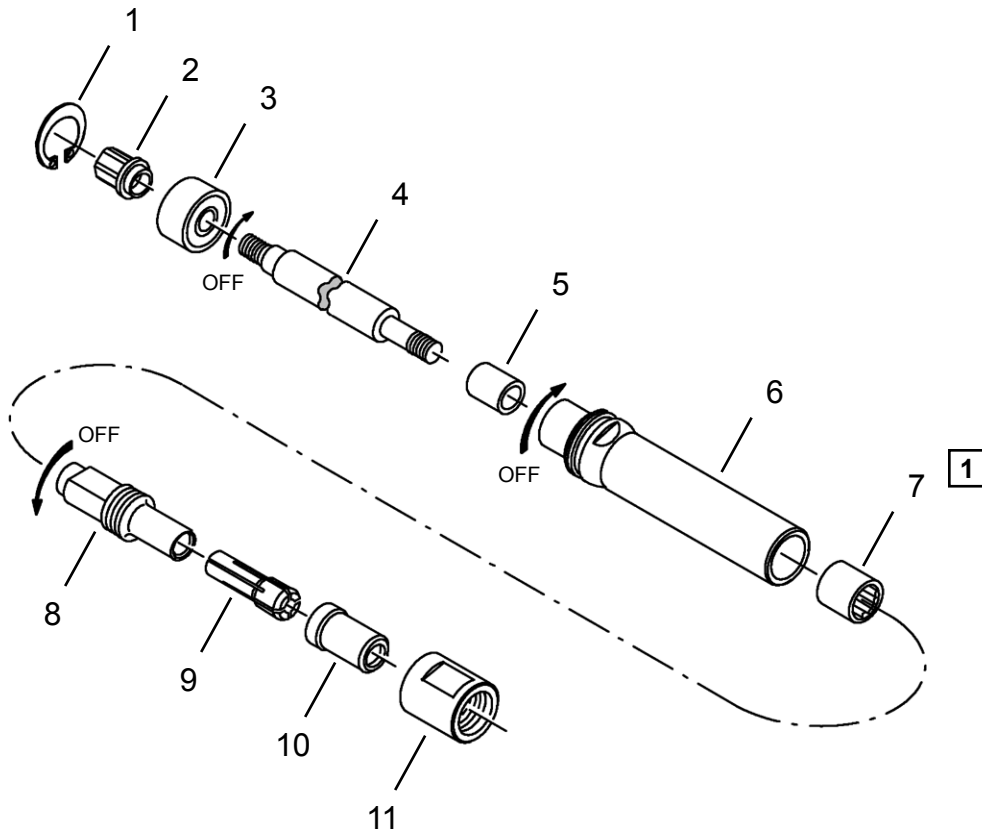

**1** Press replacement bearing 1/4" below the end of the spindle housing.



**3" and 5" Extension Assemblies**

**Illustration "C"**

Ref	Number	#	X	EN
				Description
1	1098	1	K7	Retaining Ring
2	1707PT	1		Coupling Nut
3	505PT	1	K7	Ball Bearing
4	1748PT	1		Spindle (3" Extended)
	1561PT	1		Spindle (5" Extended)
5	1562	1		Sleeve
6	02-6124	1		Housing (3" Extended)
	6125PT	1		Housing (5" Extended)
7	1514PT	1	K7	Needle Bearing
8	1054PT	1		Chuck Body
9	308PT	1		Collet (1/4")
10	1053PT	1	K7	Nosepiece
11	1058PT	1	K7	Collet Chuck Cap
<b>Repair Kits</b>				
K7	04-0051	1	1	Output Kit

(#) Quantity

(X) Included in Repair Kit (K#) or Recommended Spare Parts (quantity shown based on 1-5 tools in operation)





## Sales & Service Centers

**Note:** All locations may not service all products. Please contact the nearest Sales & Service Center for the appropriate facility to handle your service requirements.

Detroit, MI

**Apex Tool Group  
Sales & Service Center**  
2630 Superior Court  
Auburn Hills, MI 48326  
Tel: 248-393-5640  
Fax: 248-391-6295

Houston, TX

**Apex Tool Group  
Sales & Service Center**  
6550 West Sam Houston  
Parkway North, Suite 200  
Houston, TX 77041  
Tel: 713-849-2364  
Fax: 713-849-2047

Lexington, SC

**Apex Tool Group**  
670 Industrial Drive  
Lexington, SC 29072  
Tel: 800-845-5629  
Tel: 803-951-7544  
Fax: 803-358-7681

Los Angeles, CA

**Apex Tool Group  
Sales & Service Center**  
6881 Stanton Avenue  
Unit B  
Buena Park, CA 90621  
Tel: 562-623-4457  
Fax: 562-802-1718

Seattle, WA

**Apex Tool Group  
Sales & Service Center**  
2865 152nd Avenue N.E.  
Redmond, WA 98052  
Tel: 425-497-0476  
Fax: 425-497-0496

York, PA

**Apex Tool Group  
Sales & Service Center**  
3990 East Market Street  
York, PA 17402  
Tel: 717-755-2933  
Fax: 717-757-5063

Canada

**Apex Tool Group  
Sales & Service Center**  
5925 McLaughlin Road  
Mississauga, Ont. L5R 1B8  
Canada  
Tel: 905-501-4785  
Fax: 905-501-4786

Germany

**Apex Tool Group  
GmbH & Co. OHG**  
Industriestraße 1  
73463 Westhausen  
Germany  
Tel: +49 (0) 73 63 81 0  
Fax: +49 (0) 73 63 81 222

England

**Apex Tool Group  
GmbH & Co. OHG**  
C/O Spline Gauges  
Piccadilly, Tamworth  
Staffordshire B78 2ER  
United Kingdom  
Tel: +44 1827 8741 28  
Fax: +44 1827 8741 28

France

**Apex Tool Group S.N.C.**  
25 rue Maurice Chevalier  
B.P. 28  
77831 Ozoir-La-Ferrière  
Cedex, France  
Tel: +33 1 64 43 22 00  
Fax: +33 1 64 43 17 17

China

**Cooper (China) Co., Ltd.**  
a company of  
Apex Tool Group, LLC  
955 Sheng Li Road,  
Heqing Pudong, Shanghai  
China 201201  
Tel: +86-21-28994176  
Fax: +86-21-51118446

Mexico

**Cooper Tools  
de México S.A. de C.V.**  
a company of  
Apex Tool Group, LLC  
Vialidad El Pueblito #103  
Parque Industrial Querétaro  
Querétaro, QRO 76220  
Mexico  
Tel: +52 (442) 211-3800  
Fax: +52 (442) 103-0443

Brazil

Cooper Tools Industrial Ltda.  
a company of  
Apex Tool Group, LLC  
Av. Liberdade, 4055  
Zona Industrial - Iporanga  
18087-170 Sorocaba  
SP Brazil  
Tel: +55 15 2383929  
Fax: +55 15 2383260

Hungary

**Apex Tool Group  
Hungaria Kft**  
Platánfa u.2  
9027 Györ  
Hungary  
Tel: +36 96 66 1383  
Fax: +36 96 66 1135

Apex Tool Group, LLC  
1000 Lufkin Road  
Apex, NC 27539  
Phone: 919-387-0099  
Fax: 919-387-2614  
www.apextoolgroup.com

# DOTCO®