



Termination -36



Terminations -14 and -16

Dotco®
Nomenclature

45-8158EN
08/24/2015

	12	X	1	0	XX	-	XX	XX	OH	LH
Product Type 12 = Ergo Handle Grinder										
Throttle Type L = Locking Lever S = Locking Lever										
Motor Size 1 = 0.3 hp										
Handle Style 0 = Straight										
Speed Options (RPM) Front Exhaust Rear Exhaust 00 = 30,000 76 = 18,000 01 = 34,000 80 = 30,000 03 = 25,000 81 = 34,000 08 = 20,000 82 = 25,000										
Termination Code 14 = 3" Cut-Off Wheel (1/4"-20 Thread) 16 = 3" Cut-Off Wheel (3/8"-24 Thread) 36 = 300 Series 3-piece collet (1/4" capacity)										
Optional Collet (no extra cost) 08 = 1/8" 14 = 7/32" M6 = 6mm										
Overhose Option (extra cost) OH = Overhose (rear exhaust models only)										
Options LH = Left Hand Rotation										

Dotco® Specifications

Model *	Exhaust	Termination	Free Speed (rpm)	Abrasive Capacity	Weight		Length		Air Inlet
					lbs.	kg	in.	mm	
12L1000-36	Front	1/4" Collet	30,000	1/2" Carbide Bur 1" Mounted Wheel	0.8	0.36	6.0	152	1/4"
12L1000-36LH	Front	1/4" Collet	30,000	1/2" Carbide Bur 1" Mounted Wheel	0.8	0.36	6.0	152	1/4"
12S1000-36	Front	1/4" Collet	30,000	1/2" Carbide Bur 1" Mounted Wheel	0.8	0.36	6.0	152	1/4"
12L1001-36	Front	1/4" Collet	34,000	1/2" Carbide Bur 1" Mounted Wheel	0.8	0.36	6.0	152	1/4"
12L1003-36	Front	1/4" Collet	25,000	1/2" Carbide Bur 1" Mounted Wheel	0.8	0.36	6.0	152	1/4"
12L1003-36LH	Front	1/4" Collet	25,000	1/2" Carbide Bur 1" Mounted Wheel	0.8	0.36	6.0	152	1/4"
12S1003-36	Front	1/4" Collet	25,000	1/2" Carbide Bur 1" Mounted Wheel	0.8	0.36	6.0	152	1/4"
12S1008-36	Front	1/4" Collet	20,000	1/2" Carbide Bur 1" Mounted Wheel	0.8	0.36	6.0	152	1/4"
12L1028-36	Rear	1/4" Collet	20,000	1/2" Carbide Bur 1" Mounted Wheel	0.8	0.36	6.0	152	1/4"
12S1028-36	Rear	1/4" Collet	20,000	1/2" Carbide Bur 1" Mounted Wheel	0.8	0.36	6.0	152	1/4"
12L1045-36	Front	1/4" Collet	12,000	1/2" Carbide Bur 1" Mounted Wheel	0.8	0.36	6.0	152	1/4"
12L1046-36	Front	1/4" Collet	18,000	1/2" Carbide Bur 1" Mounted Wheel	0.8	0.36	6.0	152	1/4"
12L1076-36OH	Rear	1/4" Collet	18,000	1/2" Carbide Bur 1" Mounted Wheel	0.8	0.36	6.0	152	1/4"
12L1080-36	Rear	1/4" Collet	30,000	1/2" Carbide Bur 1" Mounted Wheel	0.8	0.36	6.0	152	1/4"
12S1080-36	Rear	1/4" Collet	30,000	1/2" Carbide Bur 1" Mounted Wheel	0.8	0.36	6.0	152	1/4"
12L1081-36	Rear	1/4" Collet	34,000	1/2" Carbide Bur 1" Mounted Wheel	0.8	0.36	6.0	152	1/4"
12S1081-36	Rear	1/4" Collet	34,000	1/2" Carbide Bur 1" Mounted Wheel	0.8	0.36	6.0	152	1/4"
12L1082-14	Rear	3" Cut-Off Wheel	25,000	3" Cut-Off Wheel	1.5	0.70	7.7	196	1/4"
12L1082-16	Rear	3" Cut-Off Wheel	25,000	3" Cut-Off Wheel	1.5	0.70	7.7	196	1/4"
12L1082-36	Rear	1/4" Collet	25,000	1/2" Carbide Bur 1" Mounted Wheel	0.8	0.36	6.0	152	1/4"
12S1082-36	Rear	1/4" Collet	25,000	1/2" Carbide Bur 1" Mounted Wheel	0.8	0.36	6.0	152	1/4"

* Note: 12L10 and 12S10 have the same throttle configuration

Description and Instructions

The original language of this manual is English.

Product Safety Information:

Intended Use:

This pneumatic grinder is to be used only for removing material by utilizing appropriate abrasive wheels, rotary files or other material removal cutting devices.

For additional product safety information refer to Apex Tool Group, LLC or Apex Tool Group GmbH & Co. OHG document GS-2013, General Safety Pneumatic Material Removal.



The grinder must not be modified in any manner unless approved in writing by Apex Tool Group, LLC or Apex Tool Group GmbH & Co. OHG. All safety devices must be properly installed and maintained in good working order.

EC Declaration of Conformity:

We affirm that this machine is in accordance with the following EC regulations (2006/42/EC). Applied harmonized standards are ISO 12100:2010.

The name, job function and address of the person authorized to compile the technical file.

Mr. Vishnu Irigireddy
 Director of Global R&D- Mechanical Engineering
 Apex Tool Group
 670 Industrial Drive
 Lexington, SC 29072

Signature: Vishnu Irigireddy
 Date: 06/24/2015

Noise and Vibration:

Sound Level: ≤ 81 dB(A)

Vibration: < 2.5 m/s²

Air Line Lubrication:

Use Apex Tool Group, LLC or Apex Tool Group GmbH & Co. OHG's lightweight air tool oil 500021 (available in quantities shown in the following chart) or an SAE-5 lightweight spindle oil.

Part No.	Packaged	Designation
540397	1 Quart (0.94 liter)	Airlube 10W/NR-420LB DR
533485	1 US Gallon (3.78 liter)	Airlube 10W/NR-420LB DR

Air Supply Line:

Parameter	Description
Air Hose	Minimum inside diameter: 1/4" (6.4mm) Maximum length: 8.0' (2.4 m)
Working pressure range	Performance rated at: 90 psi (620 kPa)
Compressed air	Air quality according to ISO 8573-1, quality class 2.4.3 The compressed air must be clean and dry.

Service and Repair:

Tool service and repair should be performed by an authorized Apex Tool Group, LLC or Apex Tool Group GmbH & Co. OHG Center. Refer to the last page of this manual for locations.

Disposal:



Observe local disposal guidelines for all components of this tool and its packaging.

Copyright Protection:

Apex Tool Group, LLC or Apex Tool Group GmbH & Co. OHG reserves the right to modify, supplement or improve this document or the product without prior notice. This document may not be reproduced in any way, shape or form, in full or parts thereof, or copied to another natural or machine readable language or to a data carrier, whether electronic, mechanical, optical or otherwise without the express permission of Apex Tool Group, LLC or Apex Tool Group GmbH & Co. OHG

Front Exhaust Motor Assembly

“A”

Models

- 12L1000-36
- 12L1001-36
- 12L1003-36
- 12S1000-36
- 12S1003-36
- 12S1008-36
- 12L1045-36
- 12L1046-36

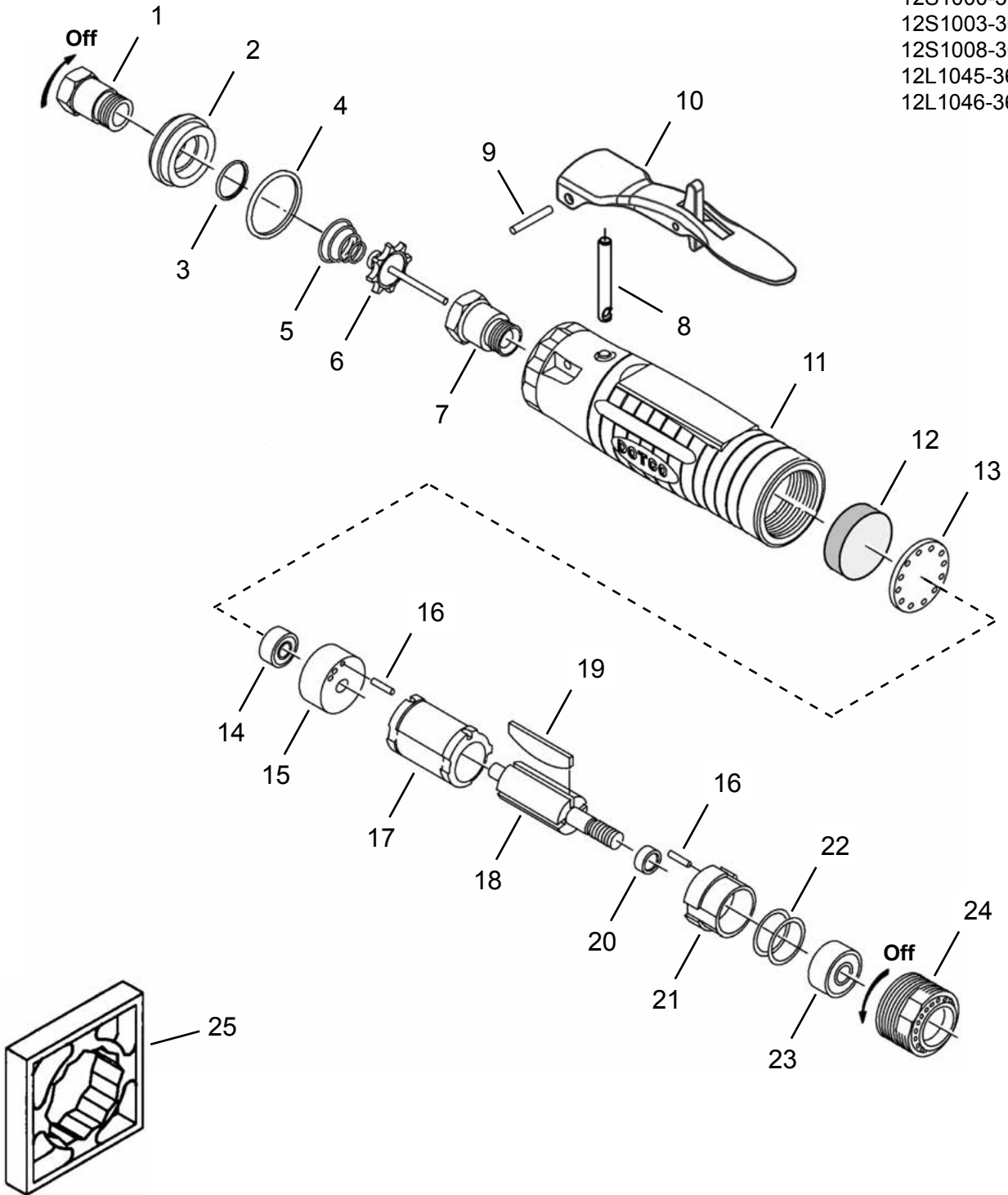

Dotco®
Front Exhaust Motor Assembly

45-8158EN
08/24/2015

Illustration "A"

Ref	Number	#	X	EN	
				Description	
1	01-2505	1	1	Air Inlet Adapter	
2	01-2506	1	1	Exhaust Plug	
3	2965	1	3	O-Ring	
4	3036PT	1	3	O-Ring	
5	01-2519	1	3	Valve Spring	
6	01-2518	1		Valve	
7	01-2504	1		Valve Seat	
8	01-1017	1		Push Rod	
9	1042	1	1	Throttle Lever Pin	
10	01-1267	1	1	Throttle Lever	
11	01-1001	1		Motor Housing	
12	01-1046	1	3	Filter Disc	
13	01-1016	1	1	Filter Retainer	
14	504PT	1	2	Ball Bearing	
15	Table "A"	1		Rear Plate (includes 1 Ref. 16)	
16	1041	2		Locating Pin	
17	1002PT	1		Cylinder	
18	Table "A"	1		Rotor	
19	Table "A"	4	12	Rotor Blade	
20	1017PT	1		Rotor Spacer	
21	Table "A"	1		Front Plate (includes 1 Ref. 16)	
22	1355	1		Shim Packet	
23	538PT	1	2	Ball Bearing	
24	Table "A"	1		Lock Ring	
25	14-0851	1		Housing Wrench (not included with tool)	

(#) Quantity

(X) Recommended Spare Parts (quantity shown based on 1-5 tools in operation)

Table "A"

Right Hand Rotation Models											
Ref.	Description	#	12L1000-36 12S1000-36	#	12L1001-36	#	12L1003-36 12S1003-36	#	12S1008-36 12L1046-36	#	12L1045-36
15	Rear Plate	1	1003PT	1	1003PT	1	1003PT	1	1003PT	1	1003PT
18	Rotor	1	1005S	1	02-1214S	1	1005S	1	1005S	1	1005S
19	Rotor Blade	4	1006PT	3	1006PT	4	1906PT	4	1906PT	4	1906PT
21	Front Plate	1	1004PT	1	1323	1	1004PT	1	1004PT	1	1004PT
24	Lock Ring	1	1014PT	1	1014PT	1	1951PT	1	2273PT	1	2172PT
Left Hand Rotation Models											
Ref.	Description	#	12L1000-36LH	#		#	12L1003-36LH	#		#	
15	Rear Plate		2157PT			1	2157PT				
18	Rotor		1005S			1	1005S				
19	Rotor Blade		1006PT			4	1906PT				
21	Front Plate		2158PT			1	2158PT				
24	Lock Ring		1014PT			1	1014PT				

Dotco®
Rear Exhaust Motor Assembly

“B”

Models

- 12L1028-36
- 12S1028-36
- 12L1076-36OH
- 12L1080-36
- 12L1081-36
- 12L1082-14
- 12L1082-16
- 12L1082-36
- 12S1080-36
- 12S1081-36
- 12S1082-36

**Overhose
Option**

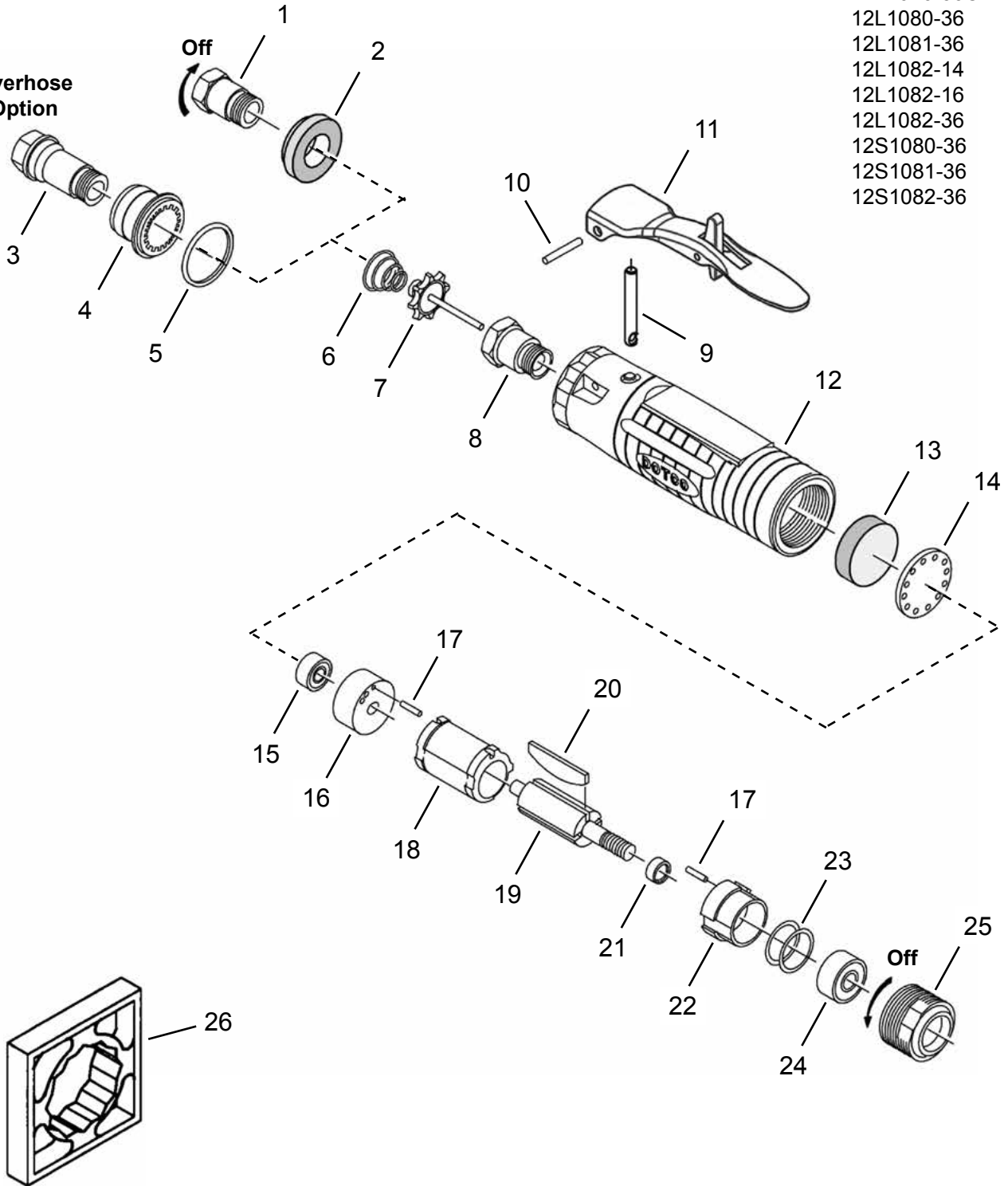

Dotco®
Rear Exhaust Motor Assembly

45-8158EN
08/24/2015

Illustration "B"

Ref	Number	#	X	EN	
				Description	
1	01-2505	1	1	Air Inlet Adapter (Rear Exhaust - no Overhose)	
2	01-2520	1	1	Diffuser (Rear Exhaust - no Overhose)	
3	01-1031	1	1	Air Inlet Adapter (Rear Exhaust - Overhose)	
4	01-1032	1	1	Muffler (Rear Exhaust - Overhose)	
5	3036PT	1	3	O-Ring (Rear Exhaust - Overhose)	
6	01-2519	1	3	Valve Spring	
7	01-2518	1		Valve	
8	01-2504	1		Valve Seat	
9	01-1017	1		Push Rod	
10	1042	1	1	Throttle Lever Pin	
11	01-1267	1	1	Throttle Lever	
12	01-1001	1		Motor Housing	
13	01-1046	1	3	Filter Disc	
14	01-1016	1	1	Filter Retainer	
15	504PT	1	2	Ball Bearing	
16	Table "B"	1		Rear Plate (includes 1 Ref. 16)	
17	1041	2		Locating Pin	
18	1002PT	1		Cylinder	
19	Table "B"	1		Rotor	
20	Table "B"	4	12	Rotor Blade	
21	1017PT	1		Rotor Spacer	
22	Table "B"	1		Front Plate (includes 1 Ref. 16)	
23	1355	1		Shim Packet	
24	538PT	1	2	Ball Bearing	
25	1045	1		Lock Ring	
26	14-0851	1		Housing Wrench (not included with tool)	
27	45-2687	1		Overhose Assembly - OH Models (4') (not shown)	

(#) Quantity

(X) Recommended Spare Parts (quantity shown based on 1-5 tools in operation)

Table "B"

Ref.	Description	#	12L1080-36		12L1081-36		12S1028-36		#	12S1028OHLH (Left Hand Rotation)
			12S1080-36	#	12S1081-36	#	12L1076-36OH	12L1082-14		
16	Rear Plate	1	1003PT	1	1003PT	1	1003PT	1	2157PT	
19	Rotor	1	1005S	1	02-1214S	1	1005S	1	1005S	
20	Rotor Blade	4	1006PT	3	1006PT	4	1906PT	4	1906PT	
22	Front Plate	1	1004PT	1	1004PT	1	1004PT	1	2158PT	

“C” Termination -36 (1/4” Collet)

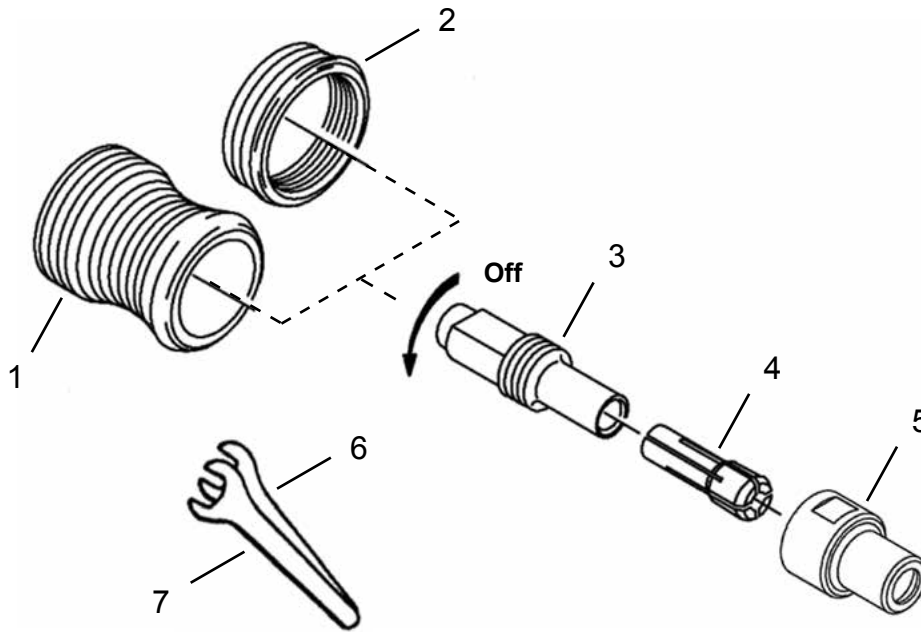

“D” Terminations -14 and -16 (3” Cut-Off Wheel)

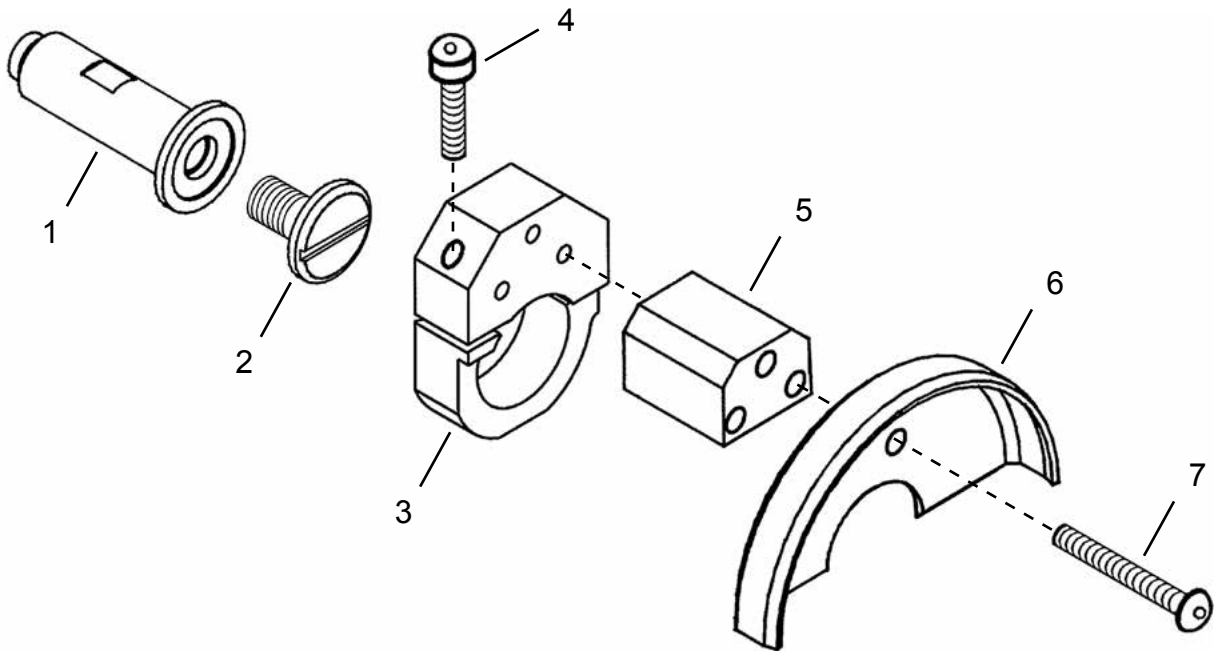

Illustration "C"

Ref	Number	#	X	EN
				Description
1	01-1047	1		Collet Guard (Long)
2	01-1050	1		Collet Guard (Short)
3	1054PT	1	2	Collet Chuck Body
4	308PT	1	2	Collet (1/4")
5	208196PT	1	2	Collet Nosepiece Cap
6	14-0807	1		Wrench (7/16")
7	14-0811	1		Wrench (11/16")

(#) Quantity

(X) Recommended Spare Parts (quantity shown based on 1-5 tools in operation)

Illustration "D"

Ref	Number	#	X	EN
				Description
1	14-1036	1		Cut-Off Wheel Adapter (Termination -14)
	14-1037	1		Cut-Off Wheel Adapter (Termination -16)
2	14-1038	1	1	Cut-Off Wheel Adapter Screw - 1/4-20 (Termination -14)
	14-1039	1	1	Cut-Off Wheel Adapter Screw - 3/8-24 (Termination -16)
--	14-1018	1		3" Cut-Off Wheel Guard (includes Ref. 3-7)
3	14-1040	1		Guard Clamp
4	14-1108	1	1	Socket Head Cap Screw (#10-32 x .75)
5	14-1041	1		Guard Spacer
6	14-1258S	1		3" Type 1 Guard Hood
7	14-1042	3	3	Button Head Cap Screw (#10-32 x 1.5)

(#) Quantity

(X) Recommended Spare Parts (quantity shown based on 1-5 tools in operation)

POWER TOOLS SALES & SERVICE CENTERS

Please note that all locations may not service all products.

Contact the nearest Apex Tool Group Sales & Service Center for the appropriate facility to handle your service requirements.

NORTH AMERICA | SOUTH AMERICA

Detroit, Michigan

Apex Tool Group
2630 Superior Court
Auburn Hills, MI 48236
Phone: +1 (248) 393-5640
Fax: +1 (248) 391-6295

Lexington, South Carolina

Apex Tool Group
670 Industrial Drive
Lexington, SC 29072
Phone: +1 (800) 845-5629
Phone: +1 (919) 387-0099
Fax: +1 (803) 358-7681

Louisville, Kentucky

Apex Tool Group
1000 Glengarry Drive
Suite 150
Fairdale, KY 40118
Phone: +1 (502) 708-3400
apexpowertools.com/service

Canada

Apex Tool Canada, Ltd.
7631 Bath Road
Mississauga, Ontario L4T 3T1
Canada
Phone: (866) 691-6212
Fax: (905) 673-4400

Mexico

Apex Tool Group
Manufacturing México
S. de R.L. de C.V.
Vialidad El Pueblito #103
Parque Industrial Querétaro
Querétaro, QRO 76220
Mexico
Phone: +52 (442) 211 3800
Fax: +52 (800) 685 5560

Brazil

Apex Tool Group
Ind. Com. Ferram, Ltda.
Av. Liberdade, 4055
Zona Industrial Iporanga
Sorocaba, São Paulo
CEP# 18087-170
Brazil
Phone: +55 15 3238 3820
Fax: +55 15 3238 3938

EUROPE | MIDDLE EAST | AFRICA

England

Apex Tool Group
GmbH & Co. OHG
C/O Spline Gauges
Piccadilly, Tamworth
Staffordshire B78 2ER
United Kingdom
Phone: +44 1827 8727 71
Fax: +44 1827 8741 28

France

Apex Tool Group S.A.S.
25 rue Maurice Chevalier
B.P. 28
77831 Ozoir-La-Ferrière
Cedex, France
Phone: +33 1 64 43 22 00
Fax: +33 1 64 43 17 17

Germany

Apex Tool Group
GmbH & Co. OHG
Industriestraße 1
73463 Westhausen
Germany
Phone: +49 (0) 73 63 81 0
Fax: +49 (0) 73 63 81 222

Hungary

Apex Tool Group
Hungária Kft.
Platánfa u. 2
9027 Győr
Hungary
Phone: +36 96 66 1383
Fax: +36 96 66 1135

ASIA PACIFIC

Australia

Apex Tool Group
519 Nurigong Street, Albury
NSW 2640
Australia
Phone: +61 2 6058 0300

China

Apex Power Tool Trading
(Shanghai) Co., Ltd
Building A8, No. 38
Dongsheng Road
Pudong, Shanghai
China 201201
Phone: +86 21 60880320
Fax: +86 21 60880298

India

Apex Power Tools India
Private Limited
Gala No. 1, Plot No. 5
S. No. 234, 235 & 245
Indialand Global
Industrial Park
Taluka-Mulsi, Phase I
Hinjawadi, Pune 411057
Maharashtra, India
Phone: +91 020 66761111

Japan

Apex Tool Group Japan
Korin-Kaikan 5F,
3-6-23 Shibakoen, Minato-Ku,
Tokyo 105-0011, JAPAN
Phone: +81-3-6450-1840
Fax: +81-3-6450-1841

Korea

Apex Tool Group Korea
#1503, Hibrand Living Bldg.,
215 Yangjae-dong,
Seocho-gu, Seoul 137-924,
Korea
Phone: +82-2-2155-0250
Fax: +82-2-2155-0252

Apex Tool Group, LLC

1000 Lufkin Road
Apex, NC 27539
Phone: +1 (919) 387-0099
Fax: +1 (919) 387-2614
www.apexpowertools.com

DOTCO®